



M110800E.1

ITEM NUMBER: 110800, 110900,
1131

SERIAL NUMBER: _____

Owner's Manual

Instructions for Assembly, Testing, Operation, Servicing and Storage

24, 30, 37-Ton Log Splitters: Outdoor hydraulic powered machine that splits wood logs.

WARNING

READ and UNDERSTAND this manual completely before using log splitter.

All operators of this equipment must read and completely understand all safety information, operating instructions, maintenance and storage instructions. Failure to properly operate and maintain the log splitter could result in serious injury to the operator and bystanders from moving parts that can crush or cut, flying objects, burns, fire or explosion, escaping high pressure hydraulic fluid, or carbon monoxide poisoning in particular, be aware of the following hazards.

Crush and Cut Hazards

Moving parts can crush and cut hands and fingers. Keep hands clear of endplate, wedge, logs, and log strippers while splitting.

High Pressure Hydraulic Fluid Hazards

High fluid pressures and temperatures are developed in hydraulic log splitters. Hydraulic fluid escaping through even a pin-size hole opening can puncture skin and cause severe blood poisoning. Inspect hydraulic system regularly for possible leaks. Never check for leaks with your hand while the system is pressurized. Seek medical attention immediately if injured by escaping fluid.

Fire Hazards

- If your log splitter is intended for use near an ignitable forest, brush, or grassy covered land, the engine exhaust should be equipped with a spark arrestor. See the "Specifications" section of this manual to determine if your splitter already has a spark arrestor. If not equipped, call NorthStar Product Support for ordering information.
- Keep a fire extinguisher with you that is rated for ordinary combustibles and flammable liquids.

STOP!

ADD OIL TO ENGINE BEFORE USING: Engine is shipped without oil. DO NOT start log splitter without first adding oil.

ADD HYDRAULIC OIL: Your log splitter was shipped without hydraulic oil. Refer to Periodic Maintenance section of this manual for instructions on filling the hydraulic reservoir

PRIME THE PUMP: The pump on your log splitter needs to be primed before use. Refer to Initial Setup section for instructions.

INSPECT COMPONENTS: Closely inspect to make sure no components are missing or damaged.

See Initial Unpacking and Set-up for instructions and for whom to contact to report missing or damaged parts.

Any Questions, Comments, Problems or Parts Orders
Call NorthStar Product Support 1-800-270-0810

Hazard Signal Word Definitions





	<p>This is the safety alert symbol. It is used to alert you to potential personal injury hazards. Obey all safety messages that follow this symbol to avoid possible injury or death.</p>
	<p>DANGER (red) indicates an imminently hazardous situation which, if not avoided, will result in death or serious injury.</p>
	<p>WARNING (orange) indicates a potentially hazardous situation which, if not avoided, could result in death or serious injury.</p>
	<p>CAUTION (yellow) indicates a potentially hazardous situation which, if not avoided, may result in minor or moderate injury.</p>
	<p>CAUTION (yellow) used without the safety alert symbol indicates a potentially hazardous situation which, if not avoided, may result in property damage.</p>

fig01453

Table of Contents

Hazard Signal Word Definitions.....	2
Table of Contents.....	3
About Your Log Splitter	4
Safety Label Locations	5
Machine Component Identification	8
Initial Setup.....	9
Optional 4-Way Wedge Wings	11
Moving and Towing to the Job Site	12
Before Each Use — Inspection/Maintenance	15
Before Each Use - Fueling.....	18
Before Each Use – Work Site Selection and Set-up	19
Splitting Operation.....	20
Storage	26
Periodic Maintenance.....	27
Troubleshooting	28
Specifications.....	29
Parts Breakdown – Exploded View 110800, 110900, 1131 – Rev E.1	30
Summary of Important Safety information for Operation.....	33
Assembly Instructions.....	38
Limited Warranty.....	70

About Your Log Splitter

Thank you for purchasing your NorthStar log splitter!

About Your Log Splitter:

This log splitter is a machine designed to split wood logs using a hydraulically powered moving wedge. The log splitter's gasoline engine is used to pressurize the hydraulic system.

This log splitter is designed to split logs *lengthwise with the grain only*.

This log splitter model is capable of splitting logs up to 25' long and 16' in diameter.

Your splitter can be used in either a vertical or horizontal splitting position:

- When the splitter is set up to operate in the horizontal splitting position, a log is placed on the horizontal beam and the wedge moves horizontally into the end of the log to split it.
- When the splitter is set up to operate in the vertical splitting position, the log is placed on the endplate, upright on its end, and the wedge moves down into the top of the log to split it.

The horizontal splitting position is used for lighter logs that can be easily loaded onto the beam. The vertical splitting position is used for heavier logs that are difficult to load onto the beam.

The technical specifications for your log splitter are provided in the Specifications section of this manual.

WARNING

This log splitter uses a high-pressure hydraulic system to generate a very strong splitting force.

Read the manual completely before using the machine to understand how to safely operate and maintain it.

Follow all safety precautions presented throughout this manual. A summary of important safety information can be found at the end of this manual.

Contact NorthStar Product Support at 1-800-270-0810 for any questions about the appropriate use of this log splitter and/or optional accessories.

Warranty Registration:

Please fill out and submit the warranty registration card so that we have your contact information for any future product literature or replacement parts you may need.

Attention: All Rental Companies and Private Owners who loan this equipment to others!

All persons to whom you rent/loan the log splitter must have access to and read this manual. Keep this owner's manual with the splitter at all times and advise all persons who will operate the machine to read it. You must provide instruction on how to safely operate the splitter and remain available to answer any questions a renter/borrower might have.

Safety Label Locations

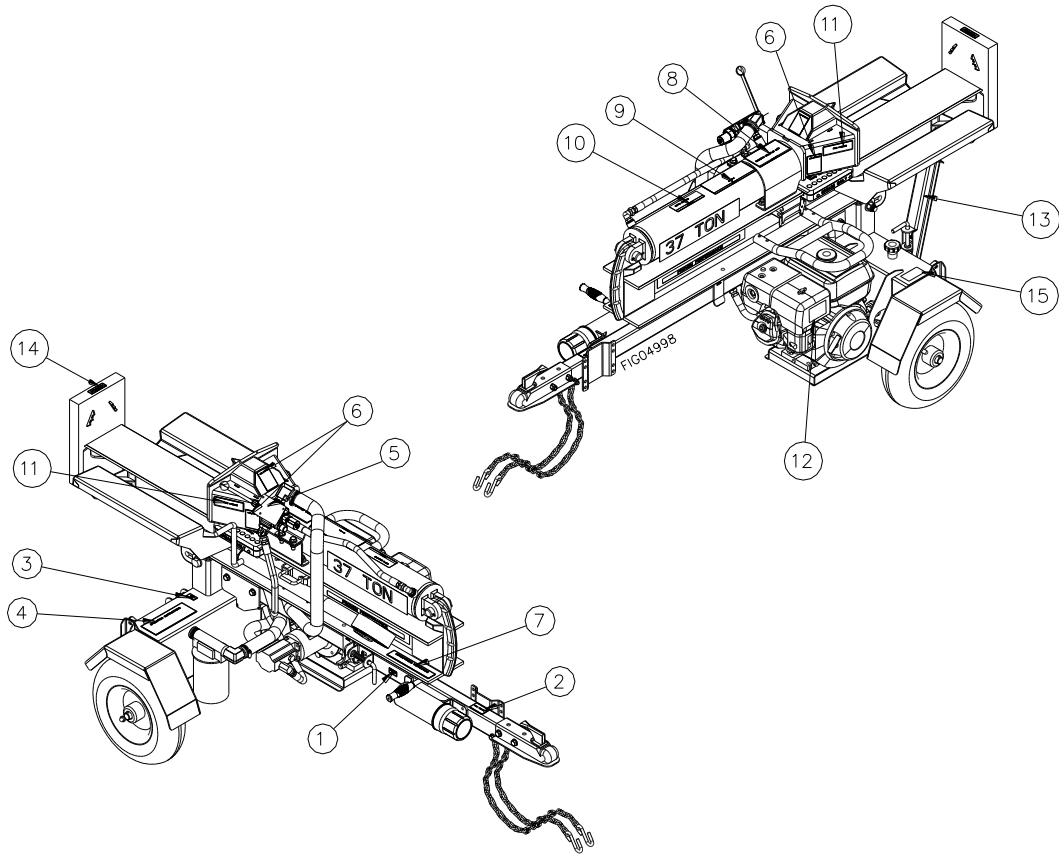

Reference #	Part Number	Description	Qty
1	778597	Decal, Horizontal Lock	1
2	791123	Decal, 45 mph	1
3	778714	Decal, Vertical Lock	1
4	777887	Decal, Operation Instructions	1
5	778609	Decal, Split Control	1
6	778717	Decal, Log Stripper	3
7	791105	Decal, Moving/Towing Instructions	1
8	778610	Decal, Log Splitter Warning	1
9	777889	Decal, Stuck Log	1
10	777891	Decal, Escaping Fluid	1
11	777890	Decal, Fire Hazard Warning	2
12	788937	Decal, Poisonous Gas Warning	1
13	791107	Decal, Outrigger Leg	1
14	787944	Decal, Pinch Point	1
15	788935	Decal, Fuel Fire Explosion Hazard	1

Always make sure safety labels are in good condition. If a safety label is missing or not legible, order new labels or unsafe operation could result. **Contact NorthStar Product Support at 1-800-270-0810**

Safety Label Locations

1 **HORIZONTAL LOCK**
PN 778597

2 **MAX TOWING SPEED**
45
MPH

3 **VERTICAL LOCK**
PN 778714

5 **SPLIT CONTROL LEVER OPERATION**

4 **OPERATING INSTRUCTIONS**

GENERAL

- Stay in the OPERATOR POSITION while actuating controls.
- Never actuate controls until the helper is 10ft away from log splitter, including any helpers assisting to load logs.
- Wear eye protection, hearing protection, snug fitting gloves, and safety shoes or heavy boots. No loose or dangling apparel.

SETTING UP

- Place log splitter on dry, level ground.
- Secure splitter for unintended movement.
- Place splitter in horizontal or vertical position.
- Start engine

SPLITTING LOG

- Position log on beam, against endplate.
- Move split control to extend wedge and split log.
- Release split control to stop wedge.
- Move split control to return wedge.
- Remove split wood from work area.

Operator Position - horizontal

Operator Position - vertical

PN 778607

6 **LOG STRIPPER**
RETRACT WEDGE TO REMOVE STUCK WOOD

WARNING

PINCH POINT
Keep hands clear of wedge and log stripper

PN 778711

7 **MOVING/TOWING INSTRUCTIONS**

Moving log splitter by hand:

- Lock beam in horizontal position (tip-up models only).
- Lock towbar leg or jack stand in DOWN position.
- Lock support leg in UP position (if equipped)
- Do not attempt to move log splitter up or down slope by hand.

Towing log splitter:

- Latch coupler securely to class 2 or higher hitch with 2" ball.
- Lock towbar leg/jack stand or support leg (if equipped) in the UP position.
- Attach safety chains to tow vehicle.
- Close fuel shut-off valve on engine (if equipped)
- Do not tow faster than 45 mph. Higher speeds can cause loss of control.
- Check local, state, and federal requirements before towing on public roads.

PN 791105

8 **WARNING**

Moving parts can crush and cut. Pieces can fly out while splitting. Follow safety rules for operating the log splitter or serious injury could result.

- READ the Owner's Manual completely before operating.
- Only one person should operate the log splitter. If an assistant is helping to load logs, the operator should not actuate controls until the assistant is at least 10 ft away.
- Stay in the designated OPERATOR POSITION while actuating the controls.
- Split wood in direction of the grain only.
- Hold bark side of logs when loading.
- Keep hands away from wedge, endplate/ram, and partly split logs.
- Never leave log splitter unattended during operation.
- Stay off slopes and slippery surfaces.

See additional safety rules in the Owner's Manual.

PN 778610

9 **WARNING**

IF LOG BECOMES STUCK ON WEDGE

A log can become stuck to the wedge if the wedge becomes embedded in the log and the log doesn't split and separate. This can happen if the log is too stringy or tough to split completely.

A stuck log will move back with the wedge on the initial attempt to retract the wedge. **If this happens, STOP retracting the wedge immediately and follow the directions below. NEVER attempt to remove a stuck log by:**

- Using the hydraulic force of the splitter
- Modifying the splitter
- Adding attachments to the splitter

Personal injury could result from log or metal pieces flying out at high speed toward the operator or bystanders, or the splitter could become damaged.

ALWAYS remove the log MANUALLY using the following procedure:

- If there is already 1" or more of clearance between the log and endplate, go to step 2. Otherwise, retract wedge just enough to remove pressure between the log and endplate - about 1" clearance.
- Turn engine OFF.
- Remove stuck log from the wedge manually with a pry bar or sledgehammer. **Important:** Be extremely careful as log pieces may fly off as they separate from the wedge. Wear safety goggles and make sure bystanders are clear.
- Do not attempt to resplit a stuck log once it has been removed from the wedge.

©2008 Northern Tool & Equipment Co. 1-800-270-0810

PN 777809

10 **WARNING**

ESCAPING HIGH PRESSURE HYDRAULIC FLUID HAZARD

High fluid pressures and temperatures are developed in the hydraulic system. Hydraulic fluid escaping through even a pin-size hole opening can puncture skin and cause blood poisoning.

- Inspect hydraulic system regularly for leaks
- Never check for leaks with your hand while system is pressurized.
- Seek medical attention immediately if injured by escaping fluid.

PN 777805

11 **WARNING**

FIRE HAZARD

Hot exhaust can ignite dry brush, trees, or grass.

- Equip engine with a spark arrestor if you will be using near ignitable forest, brush or grassy covered land.
- Keep a fire extinguisher on hand that is rated for ordinary combustibles & flammable liquids.

PN 777805

Safety Label Locations

12

⚠ WARNING	
	<p>Poisonous Gas This product gives off carbon monoxide, a poisonous gas that can kill you. You CANNOT smell it, see it, or taste it. - ONLY use outside & far away from windows, doors, & vents. - NEVER use inside homes, garages, or sheds, EVEN if you run a fan or open doors or windows. See owner's manual for more details.</p>

14

⚠ WARNING	
	<p>PINCH POINT Keep hands clear during operation.</p> 

13

OUTRIGGER LEG
<p>LOCK OUTRIGGER LEG IN THE DOWN POSITION BEFORE SPLITTING</p>

15

⚠ WARNING	
	<p>Fuel Fire/Explosion Hazard Fuel is flammable and explosive. Never fuel a running or hot engine. Clean up fuel spills immediately. Ensure there are no fuel leaks before starting. Keep sources of sparks and flames away. Hot exhaust may also ignite spilled fuel. No Smoking. Keep a fire extinguisher nearby.</p>
	
	

Machine Component Identification

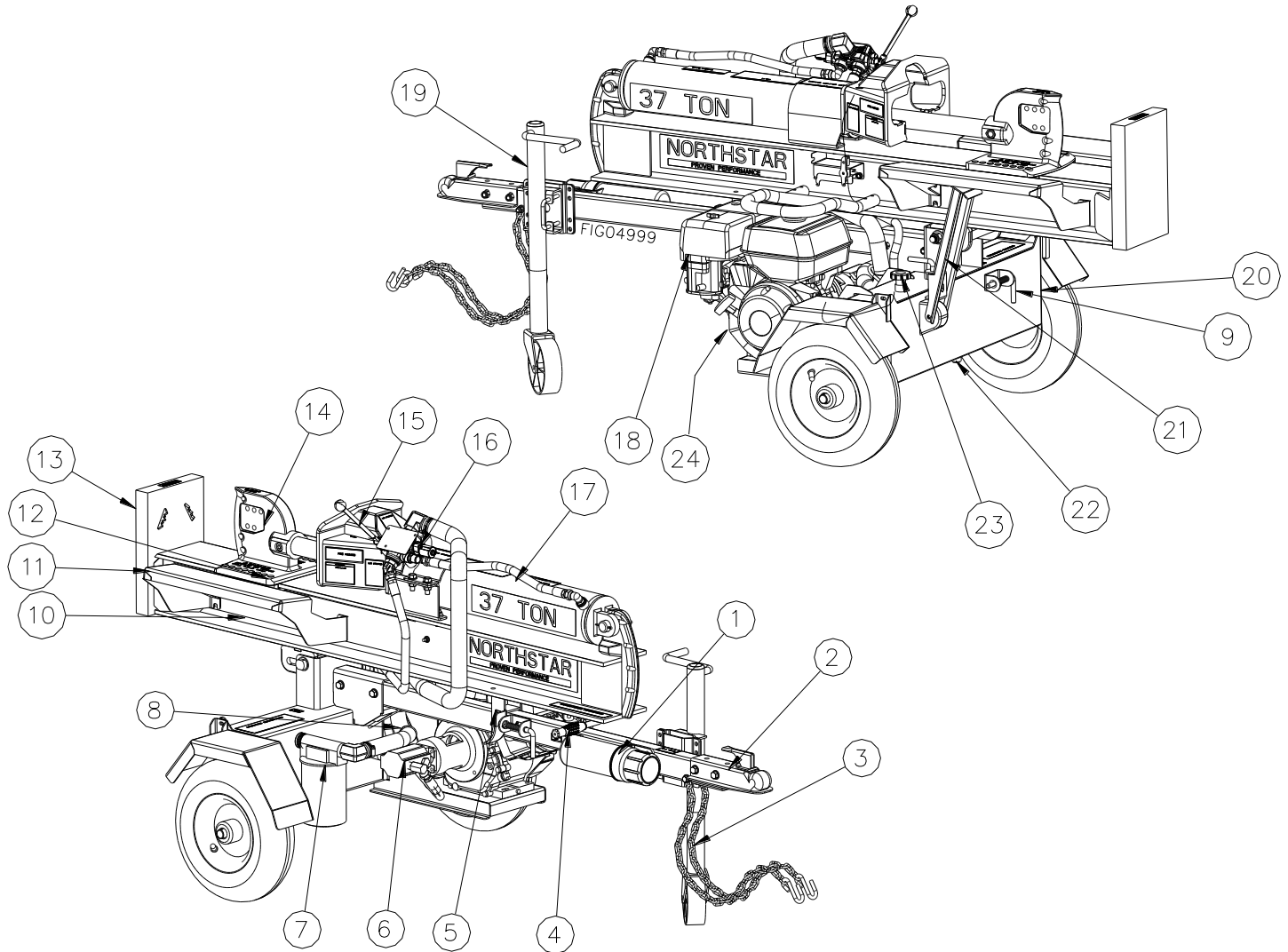

Ref #	Description
1	Manual Tube
2	2" Ball Coupler
3	Safety Chains
4	Lifting Handle
5	Horizontal Lock
6	Hydraulic Pump
7	Return Line Filter
8	Suction Strainer
9	Vertical Lock
10	Beam
11	Log Cradles
12	Grease Zerks

Ref #	Description
13	Endplate
14	Wedge
15	Split Control Lever
16	Control Valve
17	Cylinder
18	Engine
19	Jack
20	Hydraulic Tank
21	Outtrigger Leg
22	Magnetic Drain Plug
23	Breather Cap/Oil Dipstick
24	Serial Number

Initial Setup

IMPORTANT!

Engine is shipped without oil. **DO NOT** start the engine before adding oil.

See Assembly Instructions section of this manual to assemble the log splitter before setup.

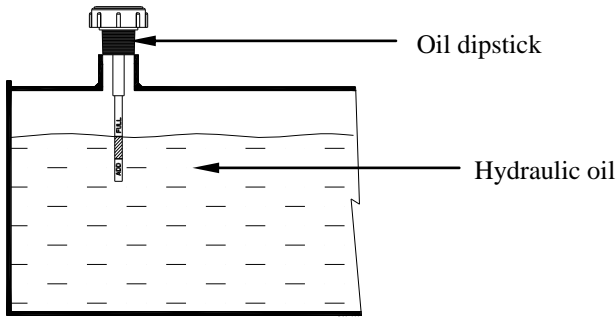
<p>Step One: Inspect Log Splitter Components.</p>	<p>Closely inspect all log splitter components. (See Machine Components section of this manual for diagram of components.)</p> <ul style="list-style-type: none">• If you have missing or damaged components, please contact Product Support at 1-800-270-0810.
<p>Step Two: Add Oil to Engine</p>	<p>Add oil to the engine. Using a funnel, add SAE 10W-30 oil up to the FULL mark on the dipstick. (See engine Owner's Manual for oil capacity and location of fill cap.)</p>
<p>Step Three: Add Hydraulic Oil to Reservoir</p>	<p>⚠ WARNING: High fluid pressures and temperatures are developed in hydraulic log splitters. Hydraulic fluid escaping through a pin hole sized opening can burn or puncture skin, resulting in wounds that could cause blood poisoning, infection, disability, gangrene, amputation, or death. Therefore, the following instructions should be heeded at all times when inspecting or servicing the hydraulic components of the log splitter.</p> <ul style="list-style-type: none">• NEVER check for leaks with your hand. Leaks can be located by holding a piece of cardboard or wood (at least two feet long) with your hand at one end and passing the other end over the suspected area (wear eye protection). Look for discoloration of the cardboard or wood.• NEVER adjust the pressure of the pump or valve.• If injured by escaping fluid, no matter how small the wound is, see a doctor at once. A typical injection injury may be a small wound that does not look serious. However, severe infection or reaction can result if proper medical treatment is not administered immediately by a doctor who is familiar with injection injuries. <ol style="list-style-type: none">1. Remove hydraulic oil dipstick.2. Refer to the Specifications section for approximate hydraulic oil capacity.3. Fill reservoir with 10 wt AW32, ASLE H-150, or ISO 32 oil. Use a funnel4. Replace hydraulic oil dipstick and check that oil level reads full. Note: Do not thread in dipstick when checking oil level.  <ol style="list-style-type: none">5. Disconnect the spark plug wire from the spark plug.6. Pull on the starter grip recoil at least 20 times so that hydraulic fluid has cycled through the pump.7. Reconnect the spark plug wire to the spark plug8. Start engine and use control valve handle to extend and retract wedge 5 (five) times to remove air from the high pressure lines.9. With wedge retracted, check oil level again.10. Replace hydraulic oil fill/vent cap.

Initial Setup

11. Start engine and use control valve handle to extend and retract wedge five (5) times to remove air from the high-pressure lines.
12. With wedge retracted, check oil level again. Fill if necessary.

⚠ WARNING: NEVER remove the hydraulic oil fill cap when the engine is running or hot. Hot oil can escape causing severe burns. Allow log splitter to cool completely before removing hydraulic oil fill cap.

Note: If the log splitter will be run for long periods of time in outdoor temperatures above 70°F, we recommend changing the hydraulic oil to DEXTRON III.

Step Four: **Lubricate Keepers**

Pump grease into grease zerks found under each keeper. This will help prevent wear between the keepers and beam.

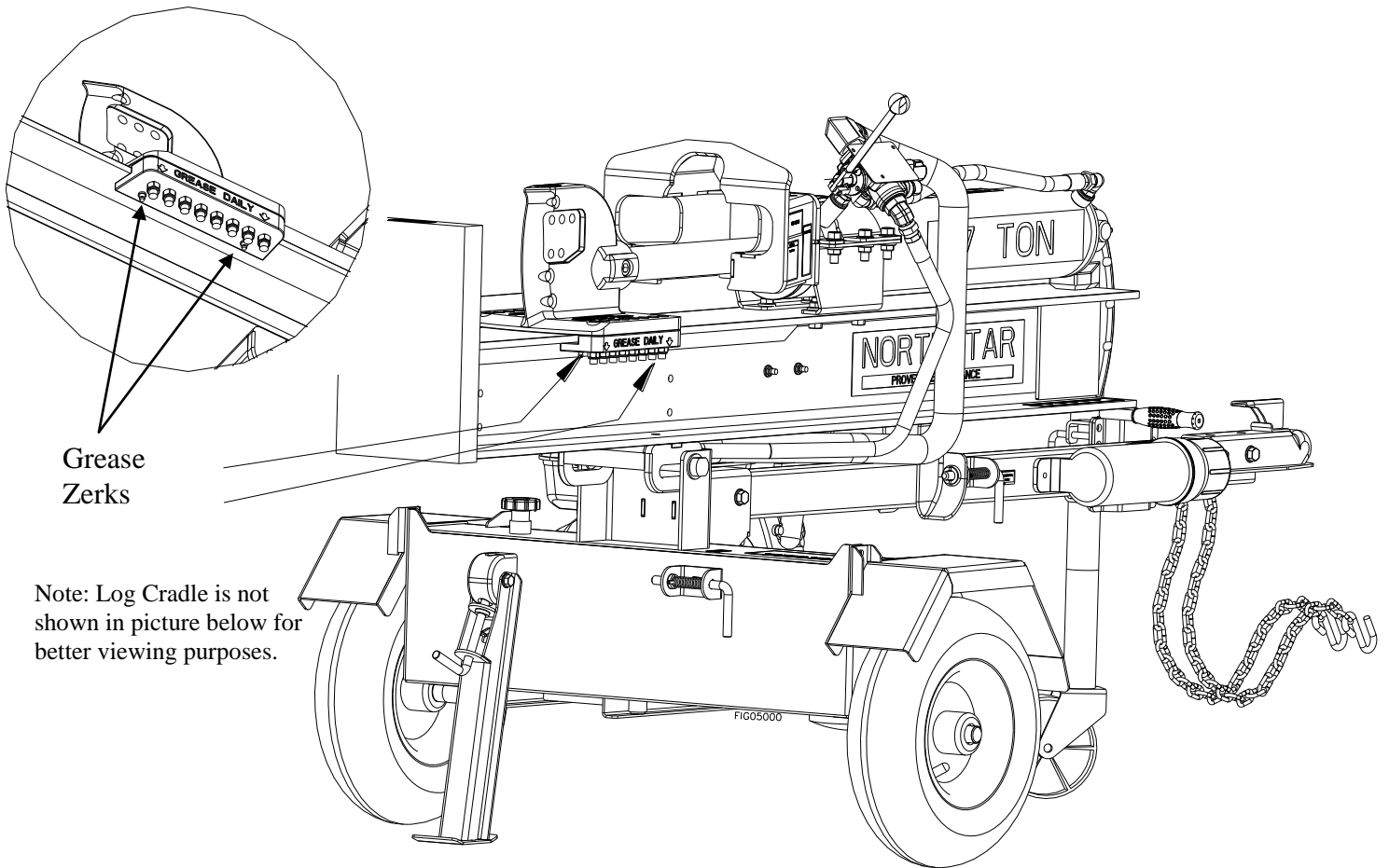

Grease
Zerks

Note: Log Cradle is not shown in picture below for better viewing purposes.

Optional 4-Way Wedge Wings

4-Way Wedge Wings (optional)

Wing Assembly

1. Unbox and identify components
2. Insert Nylon nuts into hex cutouts in wing
3. Position wings into proper locations on the wedge and bolt into position using supplied bolts
4. Tighten the bolts with a 3/8" hex wrench

Exploded View

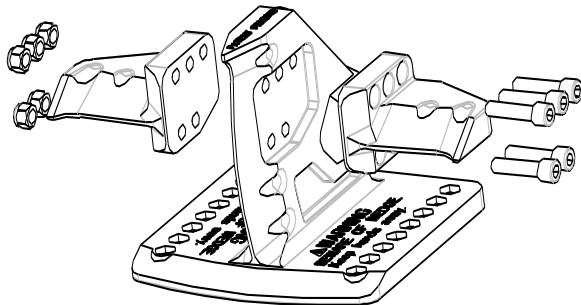

Assembled View

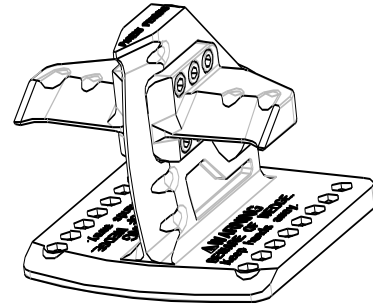

⚠ WARNING

- 4-Way Wings create additional pinch points when the wedge is moving forward or backwards. Keep hands clear of the wedge, wedge wings, and the log while the wedge is moving. When the log is caught on the wedge do not use the auto-return feature. Retract wedge manually, paying close attention so the log does not hit the engine or control valve.
- Pay particular attention to stringy wood, such as elm, because it becomes lodged on the wedge easily.

To order call: Northern Tool + Equipment at 1-800-556-7885
Item # 110910

Moving and Towing to the Job Site

⚠ WARNING

The log splitter is heavy. It can crush and cause serious injury if it rolls out of control or tips over.

Follow the instructions below for safely moving and towing the log splitter.

Moving the log splitter:

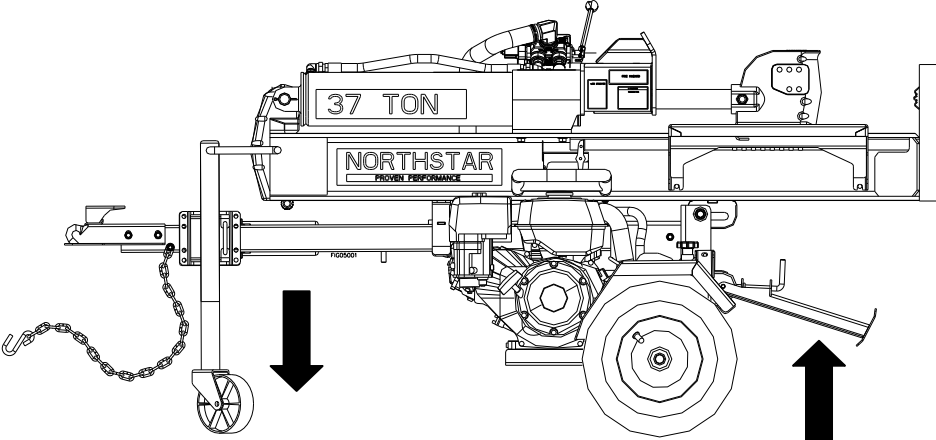
<p>1. Place in Horizontal position</p>	<p>Make sure the log splitter is locked in the horizontal position with hitch pin before moving.</p> <p>NEVER move log splitter when it is in vertical configuration because it will be unstable and could tip.</p>
<p>2. Engine off.</p>	<p>IMPORTANT: Make sure log splitter engine is off.</p> <p>Never move the log splitter with its engine running.</p>
<p>3. Fuel valve off (if equipped)</p>	<p>Turn fuel valve off to prevent carburetor flooding and reduce the chance of fuel leakage. Refer to Engine owner's manual for fuel valve location.</p>
<p>4. Lock:</p> <ul style="list-style-type: none"> • Front <u>jack</u> <u>DOWN</u> • Rear <u>outrigger leg</u> <u>UP</u> 	<p>Lock jack in DOWN position and the rear outrigger leg in the UP position before you move the log splitter.</p>  <p style="text-align: center;"> Jack DOWN Position Outrigger UP Position </p>
<p>5. Move log splitter to work site or tow hitch</p>	<p>Move log splitter by hand either directly to chosen work site or to vehicle hitch for towing. (See Before Each Use: Step Three: instructions on selecting a work site)</p> <p><u>Important Safety Instructions:</u></p> <ul style="list-style-type: none"> • Hills. Do not move the log splitter up or down hills by hand—use a towing vehicle. • No riding. Never allow anyone to sit or ride on the log splitter. • No cargo. Never transport cargo or wood on the log splitter.

Moving and Towing to the Job Site

Towing:

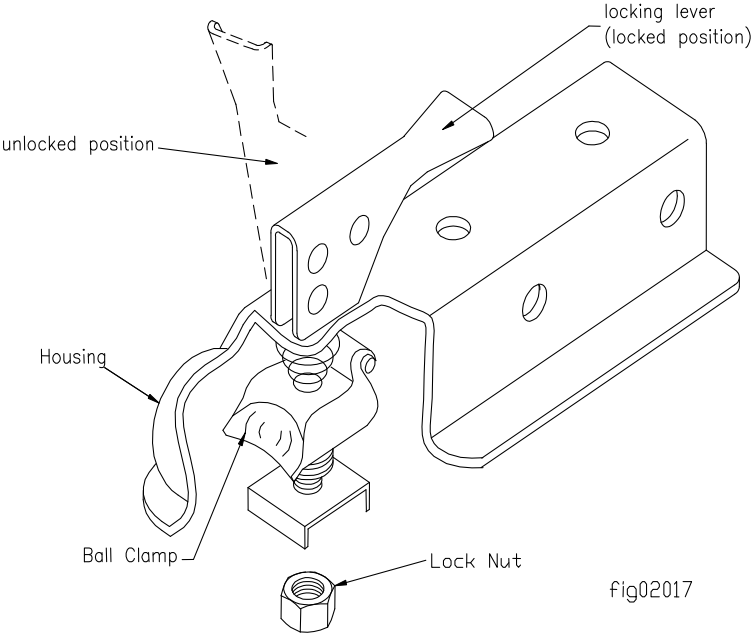
1. Read instructions	Review towing safety instructions in your vehicle manual.
2. Check tires	Make sure tires are fully inflated and in good repair. ⚠️ WARNING: <ul style="list-style-type: none">• Do not over-inflate tires. Serious injury can occur if tire explodes.• When seating a bead after repair, do not exceed 30 PSI. Pressures higher than 30 PSI can cause the tire and wheel to rupture and explode.
3. Attach to hitch (2" ball)	Attach log splitter to vehicle hitch <ol style="list-style-type: none">1. Attach log splitter's coupler to a class 2 or higher hitch with 2" ball (only).2. Adjust coupler to ball by raising locking lever and turning lock nut with fingers.3. Proper adjustment is obtained when coupler is as tight as possible on ball and locking lever can still be opened and closed.4. Lock lever closed to secure the attachment. An optional locking pin or padlock may be inserted in the locking lever hole for extra security. 
4. Attach safety chains	Attach safety chains. <ol style="list-style-type: none">1. Two safety chains must be used while towing.2. Cross safety chains under the coupler allowing only enough slack for vehicle turns.

Moving and Towing to the Job Site

5. Lock jack and outrigger leg UP

Move the **front outrigger leg to the UP position and lock**. (Both outrigger legs must remain in the up position during towing.)

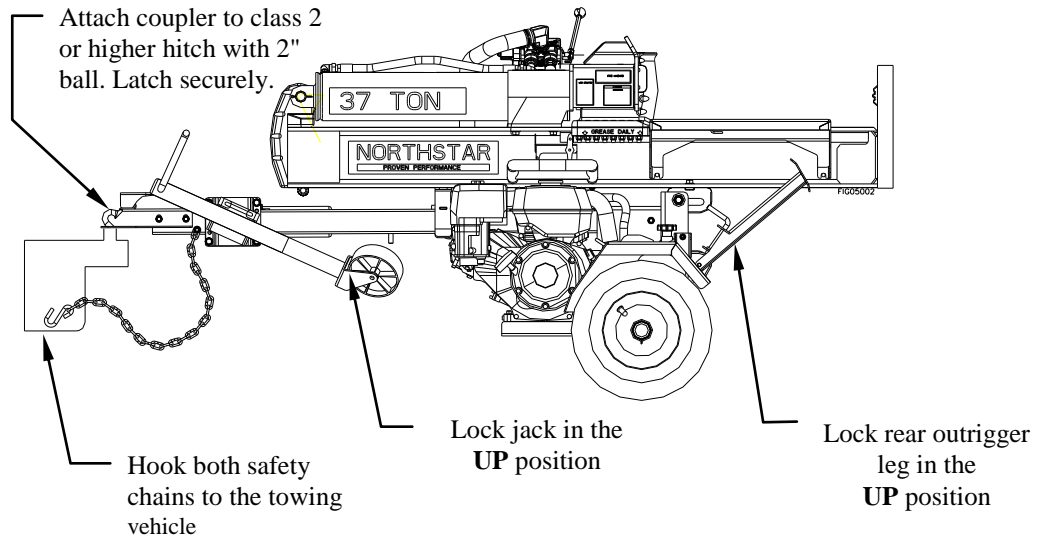

6. Tow to desired location

Tow log splitter carefully to desired work site.
(See Before Each Use section on selecting an appropriate work site)

Important safety instructions:

- **Added length.** Be aware of the added length of the splitter.
- **Speed limit.** Never tow this log splitter over 45 mph. Faster speeds may result in loss of control.
- **Rough terrain.** Drive slowly and take extra caution when traveling over rough terrain.
- **On public roads.** If towing on a public road, make sure to comply with all local, state, and federal towing requirements. It is the sole responsibility of the purchaser to obtain licensing, trailer lights, safety chains or signage, as needed to comply.
- **Unattended.** Turn off the towing vehicle before leaving the splitter unattended.
- **Under the influence.** Never tow or operate this splitter while under the influence of alcohol, drugs, or medication.

7. Lock front outrigger leg down and unhitch

Lock front outrigger leg in the DOWN position and disconnect from vehicle.
NEVER operate log splitter while it is attached to the vehicle.

Before Each Use — Inspection/Maintenance

Step One: Inspect and maintain log splitter before each use

If the log splitter has been used previously, it must be inspected and maintained BEFORE EACH SUBSEQUENT USE.

! WARNING

ALWAYS shut off the engine, disconnect the spark plug, and relieve system pressure before inspecting, cleaning, adjusting, or repairing the splitter. Relieve system pressure by moving Split Control Lever back and forth several times.

IMPORTANT:

If a part needs replacement, only use parts that meet the manufacturer's specifications. Replacement parts that do not meet specifications may result in a safety hazard or poor operation of the log splitter.

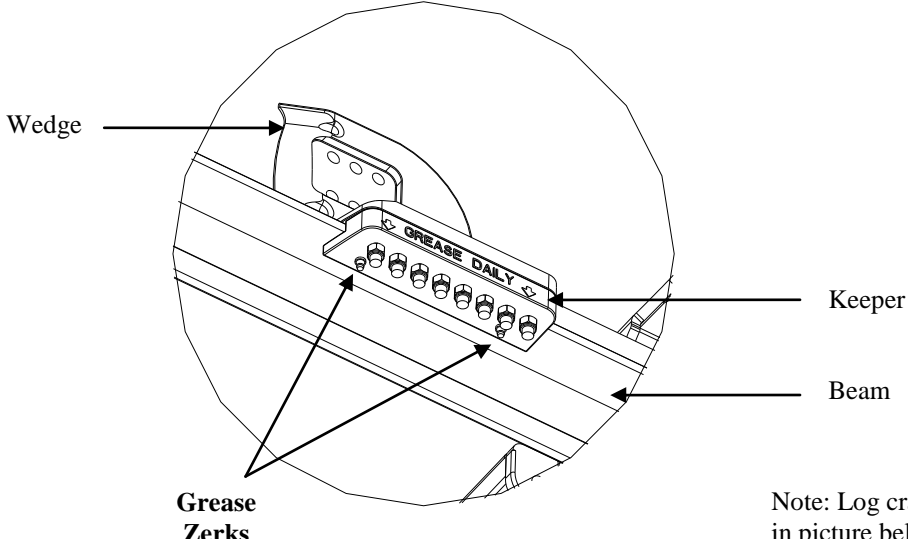
1. Engine off / relieve pressure	<p>Perform all inspections/repairs with the engine off and hydraulic system pressure relieved.</p> <ol style="list-style-type: none"> 1. Make sure engine is off and cool. 2. Disconnect the spark plug 3. Relieve all hydraulic system pressure by moving the Split Control Lever back and forth several times.
2. Remove debris	<p>Remove debris from engine, muffler, and moving parts.</p> <ol style="list-style-type: none"> 1. <u>Engine debris.</u> Debris on a hot engine can be a fire hazard. Clean debris and chaff from engine cylinder head, cylinder head fins, blower housing rotating screen, and muffler areas. Avoid contact with hot muffler. 2. <u>Other debris.</u> Debris on moving parts can cause excess wear. Clear debris from the slide beam, wedge, and endplate.
3. Fuel tank / lines	<p>Check fuel tank and fuel lines for leaks.</p> <p>Any fuel leak is a fire hazard. Fix any fuel leaks before starting engine.</p>
4. Mechanical parts	<p>Check to be sure that all nuts and bolts are tight to make sure the log splitter is in safe working condition.</p> <p>Apply grease to grease zerks under both keepers.</p> <div style="text-align: center; margin-top: 20px;">  <p style="margin-left: 20px;">Wedge</p> <p style="margin-left: 350px;">Grease Zerks</p> <p style="margin-right: 20px;">Keeper</p> <p style="margin-right: 20px;">Beam</p> </div> <p style="text-align: right; margin-top: 20px;">Note: Log cradle is not shown in picture below for better viewing purposes</p>

Before Each Use — Inspection/Maintenance

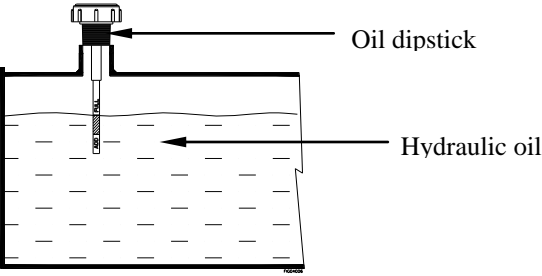
5. Hydraulic system	<p>Check the hydraulic system carefully:</p> <ol style="list-style-type: none"> 1. Visually inspect all hoses, tubing, clamps/fittings, pump, and cylinder for cracks, fraying, kinks, or other damage. 2. Check all components for oily residue, which may indicate a leak. <p>Do NOT operate the log splitter if there is any indication of damage or oily residue. Small leaks in hydraulic lines can cause severe injuries and can also be an indication of catastrophic failure in the near future. The life of hydraulic hoses may be from a few months to a few years, depending on use and storage patterns.</p> <p>⚠ WARNING: High fluid pressures and temperatures are developed in hydraulic log splitters. Hydraulic fluid escaping through a pin hole sized opening can burn or puncture skin, resulting in wounds that could cause blood poisoning, infection, disability, gangrene, amputation, or death. Therefore, the following instructions should be heeded at all times when inspecting or servicing the hydraulic components of the log splitter:</p> <ul style="list-style-type: none"> • Stop the engine, disconnect the spark plug, and move all control valve handles back and forth to relieve pressure before changing or adjusting hydraulic system components such as hoses, tubing, fittings or other components. • NEVER check for leaks with your hand. Leaks can be located by holding a piece of cardboard or wood (at least two feet long) with your hand at one end and passing the other end over the suspected area (wear eye protection). Look for discoloration of the cardboard or wood. • NEVER adjust the pressure setting of the pump or valve. • If injured by escaping fluid, no matter how small the wound is, see a doctor at once. A typical injection injury may be a small puncture wound that does not look serious. However, severe infection or reaction can result if proper medical treatment is not administered immediately by a doctor who is familiar with injection injuries.
6. Hydraulic oil level	<p>Check the hydraulic oil level. Fill as needed – check that oil level reads full. Note: Do not thread in dipstick when checking oil level.</p> <div style="text-align: center; margin: 10px 0;">  </div> <p>⚠ WARNING: NEVER remove the hydraulic oil dipstick when the engine is running or hot. Hot oil can escape causing severe burns. Allow log splitter to cool completely before removing hydraulic oil dipstick.</p>
7. Engine	Inspect and perform engine maintenance as directed in the engine manual.
8. Spark arrestor muffler	<p>If the engine is equipped with a spark arrestor muffler, clean and inspect it regularly (follow spark arrestor manufacturer's service instructions).</p> <p>Replace if damaged.</p>

Before Each Use — Inspection/Maintenance

9. Tires

Make sure tires are fully inflated and in good repair if you will be towing the splitter.

See tire sidewall for recommended tire pressure.

 WARNING:

- Do not over-inflate tires. Serious injury can occur if tire explodes.
- When seating a bead after repair, do not exceed 30 PSI. Pressures higher than 30 PSI can cause the tire and wheel to rupture and explode.

10. Shields / guards

Replace all guards and shields after servicing the log splitter.

Before Each Use - Fueling

Step Two: Fueling

⚠ WARNING

Gasoline is highly flammable and explosive. You can be burned or seriously injured when handling fuel. Use extreme care when handling gasoline.

1. Engine off / cool	<p>The engine must be off and allowed to cool at least two minutes before adding fuel.</p> <p>⚠ WARNING: A running engine is hot enough to ignite fuel. Never add fuel or remove gas cap if engine is running or still hot.</p>
2. Outdoor location	<p>Fill fuel tank outdoors – never indoors.</p> <p>⚠ WARNING: Gasoline vapors can ignite if they collect inside an enclosure. Explosion can result.</p>
3. Remove gas cap	<p>Remove engine gas cap.</p>
4. Add gasoline	<p>Add gasoline through fill opening from a UL listed container.</p> <p><u>Important Safety Instructions:</u></p> <ul style="list-style-type: none"> • Use approved container. NEVER pump fuel directly into engine at gas station. Static charge can build and ignite fuel. Use a UL listed fuel container to transfer gas to the engine. • Don't overfill. DO NOT overfill the gas tank. Allow at least 1/2" of empty space below the fill neck to allow for fuel expansion • Heat / flames / sparks. Stay away from sources of heat, flame, or sparks while adding fuel. <div style="float: right; border: 2px solid black; padding: 5px; margin-top: 10px;"> <p style="text-align: center; font-weight: bold; font-size: 1.2em;">WARNING</p> <p style="font-size: 0.8em;">FEDERAL LAW prohibits the use of E15 in small engines. Per the EPA, E15 should ONLY be used in 2001 and newer passenger vehicles.</p> <div style="text-align: center;">  </div> <p style="text-align: right; font-size: 0.6em;">790134</p> </div>
5. Spills / splashes	<p>Clean up fuel spills /splashes immediately.</p> <ol style="list-style-type: none"> 1. Move the log splitter away from spilled fuel on the ground. 2. Wipe fuel off engine and wait 5 minutes for excess fuel to evaporate before starting engine. 3. Gas soaked rags are flammable and should be disposed of properly. 4. If gasoline is spilled on your skin or clothes, change clothes and wash skin immediately.
6. Replace gas cap	<p>Replace gas cap securely before starting engine.</p>
7. Gasoline storage	<p>Store extra gasoline in a cool, dry place in a UL listed, tightly sealed container.</p>

Before Each Use – Work Site Selection and Set-up

Step Three: Work site selection and log splitter setup

⚠️ WARNING

It is important to select an appropriate work site and properly set up the log splitter in order to minimize the risk of slips and falls, equipment rolling or tipping over, carbon monoxide poisoning, and accidental fires.

1. Select location

Select an appropriate location for operating the log splitter.

Requirements:

1. Dry-level surface with good footing. Stay clear of areas with mud, ice, tall grass, weeds, brush, or snow.
2. Outdoors, away from air intakes.

⚠️ WARNING: The running engine gives off carbon monoxide, a poisonous gas that can kill you. You CANNOT smell it, see it, or taste it.

- ONLY run log splitter OUTDOORS and away from air intakes. NEVER run log splitter inside homes, garages, sheds, or other buildings or semi-enclosed spaces. These spaces can trap poisonous gases, EVEN if you run a fan or open windows.
- If you start to feel sick, dizzy, or weak while using the log splitter, shut off the engine and get to fresh air RIGHT AWAY. See a doctor. You may have carbon monoxide poisoning.

2. Fire precautions

Take the following precautions against fire:

1. **IMPORTANT:** If your splitter will be used near any unimproved forest, brush, or grassy covered land, *then engine must be equipped with a spark arrestor.*

(See the "Specifications" section of this manual to determine if your splitter already has a spark arrestor. Contact NorthStar Product Support at 1-800-270-0810 for information about obtaining a spark arrestor for your log splitter if it is unequipped.)

2. Make sure you comply with applicable local, state and federal codes.
3. Keep a fire extinguisher available (classified for both ordinary combustibles and flammable liquids) as a precautionary measure when operating the log splitter in dry areas.

3. Position splitter 7 feet from any combustibles or flammable liquids

Position muffler at least 7 ft. from combustible objects during operation.

Hot exhaust fumes from engine could cause fire. Also, hydraulic oil leaking or spraying on hot engine can ignite.

4. Lock jack and outrigger leg DOWN

Lock both the jack and outrigger leg in the **DOWN** position.

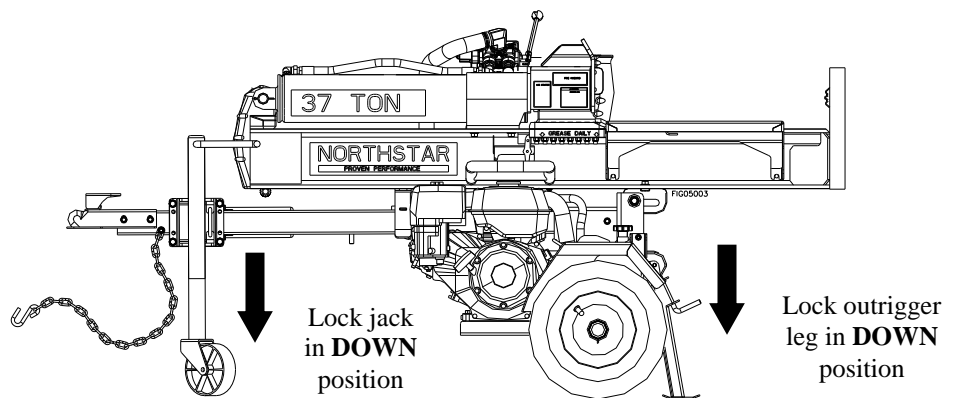

5. Block wheels

Block the wheels to prevent unintended movement of the log splitter.

6. Apply grease

Apply grease into grease zerks located under both keepers.

Splitting Operation

WARNING

Before starting this log splitter, review the following instructions and safety information for safe operation of the log splitter.

Failure to follow these rules may result in serious injury to the operator or bystanders from moving parts that crush, cut, or entangle from flying objects, burns, fire, falling or tripping, or from carbon monoxide poisoning.

General safety information:

- **Read manual.** Do not allow anyone to operate the log splitter who has not read the Owner's Manual or has not been instructed on the safe use of the splitter. The log splitter owner should instruct all operators in safe log splitter operation.
- **Age restrictions.** Never allow anyone under 16 years old to operate the log splitter. Anyone 16 years and older must be trained and supervised by a trained adult.
- **Intended use.** Log splitters should only be used for splitting wood logs, lengthwise with the grain. Do not use for other purposes as unforeseen hazards may result.
- **Modifications.** Never modify or alter the log splitter in any way. Modifications can create serious safety hazards and will void the warranty:
- **Attachments.** Never add attachments to the splitter, except for authorized accessories supplied by the manufacturer with instructions for safe installation and use.
- **Engine speed.** The maximum engine speed is preset at a safe limit. Never attempt to modify the engine speed setting to run at a higher speed.
- **Fuel/exhaust system.** NEVER modify or add to the exhaust system, fuel tanks, or fuel lines. Fire can result.
- **Remote control.** NEVER attach a rope, cable, or other remote device to the splitting control.
- **Splitting wedge.** NEVER attempt to change the height or speed of the splitting wedge.
- **Pressure setting.** NEVER increase the pressure setting of the pump or control valve.
- **Safety equipment / controls.** Always operate the log splitter with all safety equipment in place and in good working order, and all controls properly adjusted for safe operation.
- **Know how to stop.** Be thoroughly familiar with all controls and with the proper use of the equipment. Know how to stop the log splitter and relieve system pressures quickly if needed.
- **Operating speed.** Always operate the log splitter at the manufacturer's recommended speed. The maximum speed of the engine pump and wedge are preset within safe limits.
- **Daylight only.** Only use the log splitter in daylight so you can see what you are doing.
- **Smoking / sparks.** Never smoke while operating the log splitter, and never operate near sources of sparks or flames.
- **Under the influence.** Never operate, or let anyone else operate, the log splitter while under the influence of alcohol, drugs, or medication.
- **Unattended.** Never leave the machine unattended while the engine is running.
- **Refueling.** Never refuel the engine until it has cooled at least two minutes.
- **Adjusting / repairing.** Always make sure the engine is off before cleaning, repairing or adjusting the splitter, except as recommended by the manufacturer. In addition, disconnect the spark plug and move all control handles back and forth to relieve system pressure *before changing or adjusting hydraulic system components* such as hoses, tubing, fittings or other components.
- **Replace labels.** Always make sure safety labels are in place and in good condition. If a safety label is missing or not legible, order new labels because unsafe operation can result. Call 1-800-270-0810 to order new safety labels.

Splitting Operation

1. Put on protective clothing / gear

Wear the following protective clothing and safety gear:

- 1) **Eye protection.** Always wear safety glasses or goggles when operating the machine. Pieces of log may fly out and serious eye injury can occur.
- 2) **Boots.** Falling logs can crush feet. Always wear safety shoes or heavy boots when operating or helping to load logs.
- 3) **Gloves.** Wear snug fitting gloves without drawstrings or loose cuffs.
- 4) **Hearing protection.** The use of earplugs or other hearing protection device is recommended.
- 5) **No loose/dangling.** Loose or dangling apparel can become entangled in moving parts. Never wear jewelry or loose-fitting clothing.

2. Lock and block

Block the wheels to prevent unintended movement of the log splitter. Check that:

- 1) The outrigger legs are both locked in the DOWN position.
- 2) The wheels are blocked.

3. Set to horizontal or vertical:

Set log splitter into either the horizontal or vertical splitting position

The HORIZONTAL splitting position is used for lighter logs that can be easily loaded onto the beam. The VERTICAL splitting position is used for light logs as well as heavy logs that are difficult to load onto the beam.

Note:

Musculoskeletal injury can result from lifting logs onto the log splitter if proper lifting techniques are not used or the logs are too heavy for a person's size, weight, or strength. In some cases, logs as small as 8" in diameter and 14" in length may be heavier than what some persons should be repeatedly lifting onto the splitter.

The use of the vertical splitting position can greatly reduce the need to lift logs onto the splitter. Employers are advised to consider NIOSH lifting guidelines when assigning employees to log splitting tasks for an extended period of time.

⚠ WARNING: NEVER change splitting positions with the engine running. You may contact the muffler and receive serious burns.

a) Set to Horizontal position

Make sure beam is locked securely in the horizontal position by checking the horizontal lock. Jack must be locked in the down position. Rear outrigger leg must be locked in horizontal splitting position.

Horizontal Splitting Position

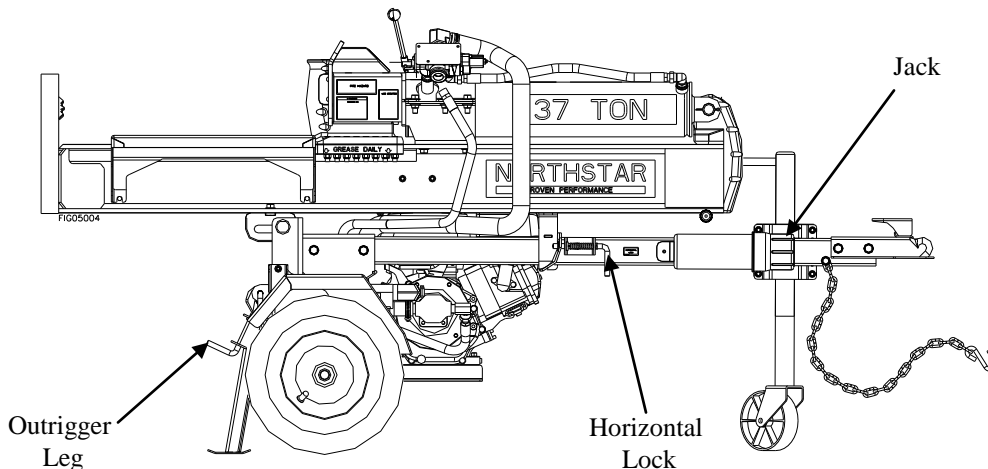

Splitting Operation

b) Set to
Vertical
position

- 1) Lock rear outrigger leg in down position.
- 2) Pull out horizontal lock catch pin, grasp lifting handle and lift beam until it rotates into vertical position.

⚠ WARNING: Crush hazard. The beam is heavy – do not let it just drop. It could crush fingers or cause damage to the splitter.

Vertical Splitting Position

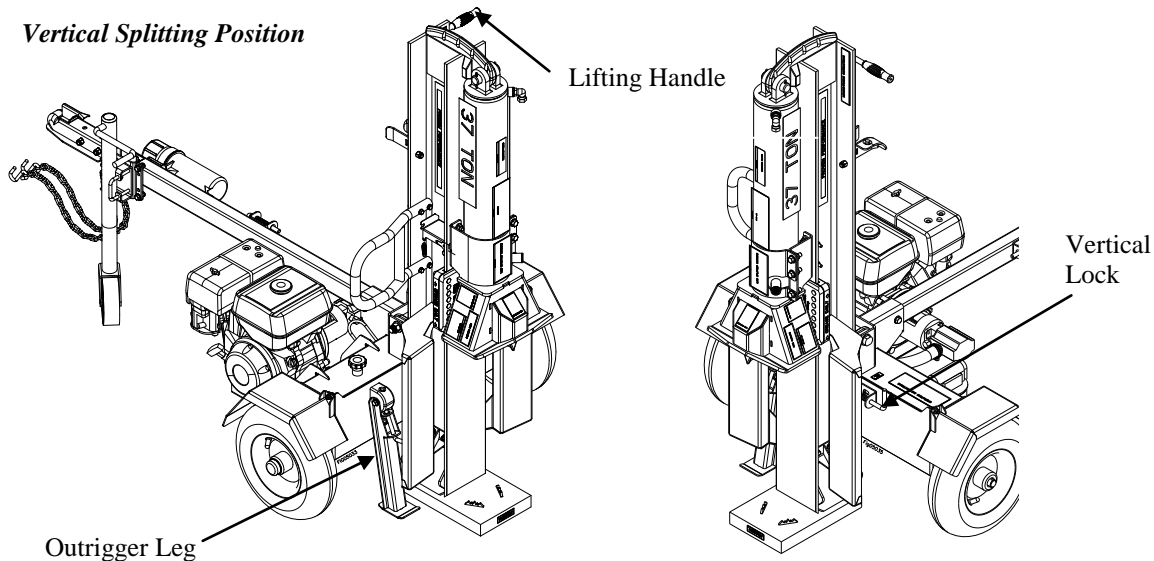

- 3) Lock in vertical position using catch pin through the vertical lock.
- 4) To return to horizontal position, unlock vertical position, grasp lifting handle and lower beam carefully in a controlled manner until it rests on the tow bar, lock beam in the horizontal position with catch pin.

4. Start engine

Start the engine.

See the engine owner's manual for engine starting instructions.

NOTE:

- a) Make sure the hydraulic oil is above 10°F before starting the engine. Cold hydraulic oil can damage the hydraulic pump.
- b) If outdoor air temperature is below 32°F, allow log splitter to warm up by extending and returning the wedge several times before splitting wood.

⚠ WARNING:

Burns. To avoid burns, stay clear of hot muffler if you are starting a warm engine.

Carbon monoxide. The running engine gives off carbon monoxide, a poisonous gas that can kill you. You CANNOT smell it, see it, or taste it. If you start to feel sick, dizzy, or weak while using the log splitter, shut off the engine and get to fresh air RIGHT AWAY. See a doctor. You may have carbon monoxide poisoning.

Other exhaust dangers. Engine exhaust, some of its constituents, and certain vehicle components contain or emit chemicals known to the State of California to cause cancer, birth defects, or other reproductive harm. Avoid inhalation of exhaust.

Splitting Operation

5. Load log

Load log onto beam with a cut end against the endplate – positioned for a lengthwise cut.

Notes:

- The log splitter is designed only for cutting lengthwise with the grain, NOT for cutting across the grain.
- This log splitter is designed for cutting logs only up to a maximum of 16" in diameter and 25" long. Larger diameter logs could get stuck on the wedge and longer logs will not fit on the beam.

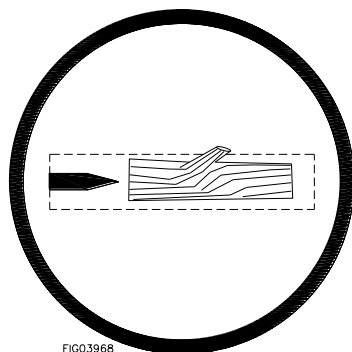
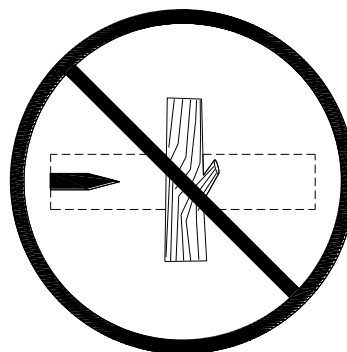
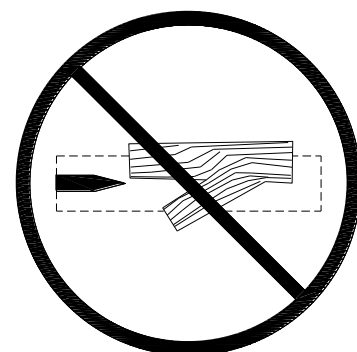

FIG03968

Correct Log Orientation



Incorrect Log Orientation



⚠ WARNING: ALWAYS keep hands and feet away from the endplate, wedge, and partially split logs while loading, operating and unloading the log splitter.

Important safety instructions:

- **Hold bark side.** Hold the bark side of logs when loading or positioning, never the ends. Never place your hands or any part of your body between a log and any part of the log splitter.
- **NOTE for vertical position loading:** Place the log on the endplate and turn it until it leans against the beam and is stable. If the log is too big or oddly shaped, stabilize the log with wooden shims between the log and endplate or ground. DO NOT use your leg or knee to stabilize the log. NEVER stabilize the log by placing your hand on top of the log.
- **Wedge moving.** NEVER load or unload logs while the wedge is moving.
- **Straddling / reaching across.** Never straddle, reach across, or step over the beam while the engine is running and the log splitter is in the horizontal position. You could trip, actuate the controls, and get seriously injured.
- **Unsplit log pile.** Do not pile logs to be split in a place that will make you reach across the log splitter in order to load them.
- **Square log ends.** Logs that are not cut square can slide out while splitting and become a safety hazard or cause excessive force to log splitter components. Use a chainsaw to cut logs square on each end before attempting to split them.
- **Single log.** Never attempt to split more than one log at a time. Pieces of log can unexpectedly be thrown from the machine causing serious injury.
- **Split along grain.** Do not use the log splitter to split logs across the grain. Doing so will damage the log splitter and could also cause pieces of log to be thrown, injuring the operator or bystanders.
- **Forked logs.** Splitting forked logs can cause damage the log splitter. Trim the forked log with a chain saw prior to splitting the log.
- **Changing splitting position.** Do not change splitting positions (horizontal/vertical) with the engine running. You may contact the muffler and receive serious burns. Be careful to avoid contact with hot muffler even after the engine is turned off.

Splitting Operation

6. Extend wedge

Move Split Control Lever toward endplate to extend wedge and split log.

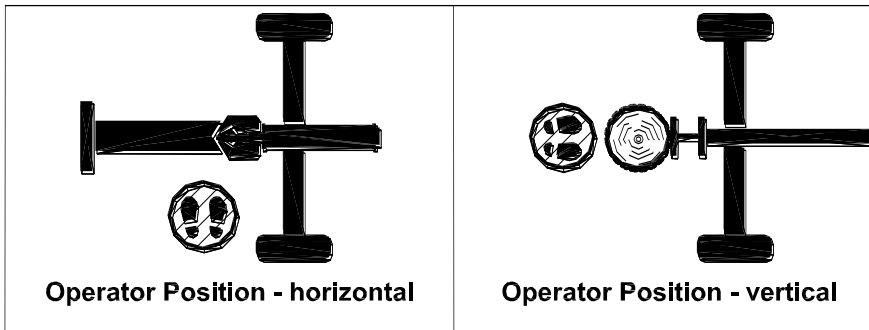
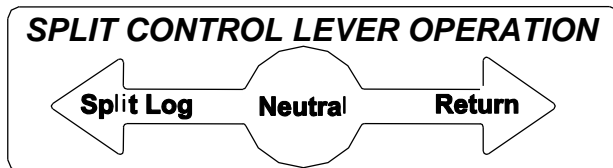

Important safety instructions:

- **Operator position.** ALWAYS operate the log splitter from the manufacturer's indicated OPERATOR POSITION. (See diagram above.) Other positions are unsafe because they can increase the risk of injury from crushing, cutting, flying objects, or burns.
- **Remove hands.** Remove both hands from log before activating Split Control Lever.
- **Hand activate.** Use only your hand to operate the Split Control Lever. Never use any other body part, or a rope, cable, or other remote device to actuate the control.
- **Second person.** Many accidents occur when there is more than one person involved in loading and operating the log splitter. Only one person should operate the controls. *If a second person is assisting in loading logs, the operator must NEVER actuate the Split Control Lever until the assistant and all bystanders are at least 10 feet away. NEVER allow an assistant to hold the log in place while the operator actuates the Split Control Lever.*

7. Stop wedge

Release Split Control Lever to stop wedge movement when log is split.

⚠ WARNING: Cracks in logs can close quickly and pinch fingers. Keep fingers away from any cracks that open in partially split logs.

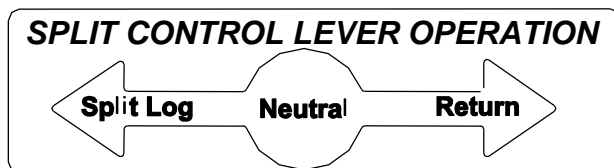

Splitting Operation

8. Important STUCK LOG procedure

If a log does not split completely and becomes stuck on the wedge, follow the instructions below to remove the log.
A log can become stuck to the wedge if the wedge becomes embedded in the log and the log doesn't split and separate. This can happen if the log is too stringy or tough to split completely. A stuck log will move back with the wedge on the initial attempt to retract the wedge. If this happens, retract the wedge completely to allow the splitter to strip the log from the wedge. Keep hands clear of log and wedge while wedge is retracting.

⚠ WARNING: NEVER attempt to remove a stuck log by:

- Modifying the splitter.
- Adding attachments to the splitter.

Personal injury could result from log or metal pieces flying out at high speed toward the operator or bystanders, or the splitter could become damaged.

9. Return wedge

Move Split Control Lever away from end plate to return wedge.

Once the control valve is actuated in the return direction, the wedge is designed to keep returning by itself completely and then stop automatically.

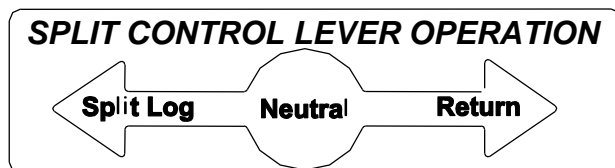

⚠ WARNING:

Stay clear while the wedge is returning. It is still powerful enough on the return stroke to cause serious injury.

10. Remove split wood

Remove split wood from area.

Move each log away from log splitter after it is split. Split logs left near the log splitter are a trip hazard.

11. After use

1. Turn off engine.

2. Remove engine debris.

Debris on a hot engine can be a fire hazard. After the engine is off, clean debris and chaff from engine cylinder head, cylinder head fins, blower housing rotating screen, and muffler areas.

⚠ WARNING: Avoid contact with hot muffler.

3. Return to horizontal position.



If in the vertical position, return log splitter to the horizontal position for greater stability and to prepare for transportation. Avoid contact with hot muffler.

Storage

WARNING

Gasoline vapors can ignite and cause a fire. Select a well-ventilated storage away from sources of heat, flame, or sparks.

Follow the instructions below for storing your log splitter between uses.

1. Retract wedge	Retract the wedge completely to keep the rod protected from corrosion.
2. Cool	Allow the machine to cool 5 minutes before storing.  WARNING: A hot engine can be a fire hazard.
3. Wipe with oily rag	Wipe the beam and wedge with an oily rag to prevent corrosion.
4. Engine manual	<p>Refer to the engine manual for proper engine storage instructions.</p> <p>CAUTION: Gasoline will oxidize and deteriorate in storage. Old gasoline in the engine will cause hard starting and leave gum deposits that can clog the fuel systems. Deterioration problems may occur within a few months, or even less if gasoline was not fresh when you filled the tank.</p> <p><u>Short-Term Storage:</u></p> <ol style="list-style-type: none"> 1. Consider adding a fuel stabilizer to extend fuel storage life. 2. Leave the fuel valve lever in the OFF position to reduce the possibility of fuel leakage. <p><u>Long-Term Storage:</u> (between infrequent uses and at end of season) Drain the fuel tank and carburetor as instructed in the engine owner's manual.</p> <p><u>Important Safety Instructions</u></p> <ul style="list-style-type: none"> • Always drain fuel from tank in outdoor, well-ventilated area. • Stay away from sources of heat, flame, or sparks while handling fuel. • Clean up fuel spills/splashes immediately.
5. Splitter storage location	<p>Store the log splitter in a location away from corrosive material, sources of heat, open flames, sparks or pilot lights.</p> <p> WARNING: Never store log splitter inside where there is a source of heat or an open flame, spark or pilot light – such as water heaters, space heaters, furnaces, clothes dryers, or other gas appliances – EVEN IF the log splitter's gas tank is empty, residual gasoline vapors could ignite.</p> <p><u>NOTE:</u> Do not store the log splitter near fertilizer or any other corrosive material.</p>
6. Gasoline storage	<p>Store gasoline in a cool, dry place in an UL approved tightly sealed container.</p> <p> WARNING: Gasoline vapors can ignite if they collect inside an enclosure and explosion can result.</p>

Periodic Maintenance

In addition to the maintenance performed with each use, periodic maintenance should also be performed according to the following schedule.

⚠ WARNING

ALWAYS shut off the engine, disconnect the spark plug, and relieve system pressure before cleaning, adjusting, or repairing the splitter. Relieve system pressure by moving Split Control Lever back and forth several times.

Important:

If a part needs replacement only use parts that meet the manufacturer's specifications. Replacement parts that do not meet specifications may result in a safety hazard or poor operation of the log splitter.

1. Engine maintenance	Perform engine maintenance as specified in engine owner's manual.
2. Hydraulic Oil Change	Change Hydraulic Oil Annually or Every 100 Hours.
	<p>⚠ WARNING: High fluid pressures and temperatures are developed in hydraulic log splitters. Hydraulic fluid escaping through a pin hole sized opening can burn or puncture skin, resulting in wounds that could cause blood poisoning, infection, disability, gangrene, amputation, or death. Therefore, the following instructions should be heeded at all times when inspecting or servicing the hydraulic components of the log splitter.</p> <ul style="list-style-type: none"> • NEVER check for leaks with your hand. Leaks can be located by holding a piece of cardboard or wood (at least two feet long) with your hand at one end and passing the other end over the suspected area (wear eye protection). Look for discoloration of the cardboard or wood. • NEVER adjust the pressure of the pump or valve. • If injured by escaping fluid, no matter how small the wound is, see a doctor at once. A typical injection injury may be a small wound that does not look serious. However, severe infection or reaction can result if proper medical treatment is not administered immediately by a doctor who is familiar with injection injuries.
	<ol style="list-style-type: none"> 1. Use 10wt AW32, ASLE H-150, or ISO32 oil. 2. Relieve hydraulic system pressure by moving Split Control Lever back and forth several times. 3. Remove hydraulic breather cap/oil dipstick <p>⚠ WARNING: NEVER remove the hydraulic breather cap/oil dipstick when the engine is running or hot. Hot oil can escape causing severe burns. Allow the log splitter to cool completely before removing hydraulic breather cap/oil dipstick.</p> <ol style="list-style-type: none"> 4. Remove the magnetic drain plug from the hydraulic tank to drain the hydraulic oil into a 10 gallon pan. 5. Remove suction strainer and wipe off debris with a dry cloth. 6. Fill the hydraulic tank with wedge retracted. 7. Dispose of used oil at an oil-recycling center. Used hydraulic oil is hazardous waste. 8. Disconnect the spark plug wire from the spark plug 9. Pull on the starter grip recoil at least 20 times so that hydraulic fluid has cycled through the pump 10. Reconnect the spark plug wire to the spark plug 11. Extend and retract wedge 5 (five) times to purge air from the system. 12. Check hydraulic oil level and fill if necessary. Note: Do not thread in the oil dipstick when checking the hydraulic oil level.
3. Spark arrestor muffler	If the engine is equipped with a spark arrestor muffler, clean and inspect it regularly (follow manufacturer's service instructions). Replace if damaged.

Troubleshooting

⚠ WARNING

Before troubleshooting or attempting to service, read the following safety instructions to avoid serious injury to the operator or bystanders from moving parts that can crush or cut, burns, fire or explosion, or escaping high pressure hydraulic fluid.

Important Safety Instructions:

1. **Engine off.** Always make sure the engine is off before cleaning, repairing or adjusting the splitter, except as recommended by the manufacturer.
2. **Hydraulic safety.** High fluid pressures and temperatures are developed in the hydraulic log splitters. Hydraulic fluid escaping through a pin hole sized opening can burn or puncture skin, resulting in wounds that could cause blood poisoning, infection, disability, gangrene, amputation, or death. Therefore, the following instructions should be heeded at all times when inspecting or servicing the hydraulic components of the log splitter:
 - Stop the engine, disconnect the spark plug, and move all control valve handles back and forth to relieve pressure before changing or adjusting hydraulic components such as hoses, tubing, fittings, or other components.
 - Do not remove the hydraulic oil fill cap when the engine is running. Hot oil can escape causing severe burns. Allow the log splitter to cool completely before removing the hydraulic oil fill cap.
 - Do not adjust the pressure setting to the pump or valve.
 - Do not check for leaks with your hands. Leaks can be located by holding a piece of cardboard or wood (at least 2 feet long) with your hand at one end and passing the other end suspected area (wear eye protection). Look for discoloration of the cardboard or wood.
 - If injured by escaping fluid, no matter how small the wound is, see a doctor at once. A typical injection injury may be a small puncture that does not look serious. However, severe infection or reaction can result if proper medical treatment is not administered immediately by a doctor who is familiar with injection injuries.

Problem	
Wedge will not move	Solution: A,D,E,H,J
Slow wedge speed when extending or retracting	Solution: A,B,C,H,I,K
Wood will not split or splits extremely slow	Solution: A,B,C,F,I,K
Engine bogs down during splitting	Solution: G
Engine stalls under low load condition	Solution: D,E
Cause	Solution
A- Insufficient oil to pump	Check oil level in reservoir
B- Air in oil	Check oil level in reservoir, check for leaks in the suction line
C- Excessive pump inlet vacuum	Check pump inlet hose for blockage or kinks
D- Blocked hydraulic lines	Flush and clean the splitter hydraulic system
E- Blocked control valve	Flush and clean the splitter hydraulic system
F- Low control valve setting	Adjust control valve with a pressure gauge
G- High control valve setting	Adjust control valve with a pressure gauge
H- Damaged control valve	Return control valve for authorized repair
I- Internal control valve leak	Return control valve for authorized repair
J- Damaged cylinder piston	Return cylinder for authorized repair
K- Internally damaged cylinder	Return cylinder for authorized repair

Any Questions, Comments, Problems or Parts Orders

Call NorthStar Product Support 1-800-270-0810

Specifications

	110800	110900	1131
Tonnage	24 TON	30 TON	37 TON
Pressure	3500 PSI	3500 PSI	3500 PSI
Flow	11 GPM	13 GPM	16 GPM
Hydraulic Cylinder Bore	4"	4.5"	5"
Hydraulic Cylinder Stroke	24"	24"	24"
Maximum Log Length	25"	25"	25"
Maximum Log Width	16"	16"	16"
Hydraulic Fluid Type	10wt AW32, ASLE H-150, or ISO32		
Hydraulic Oil Capacity	8 GAL	8.5 GAL	9 GAL
Coupler Size	2" Ball	2" Ball	2" Ball
Maximum Towing Speed	45 MPH	45 MPH	45 MPH
Spark Arrester	No	No	Yes
Fuel Valve	No	Yes	Yes
Overall Dimensions	90" x 45" x 45" (LxWxH)		
Dry Weight	490 LB	530 LB	565 LB

The manufacturer reserves the right to make improvements in design and/or changes in specifications at any time without incurring any obligation to install them on units previously sold.

Any Questions, Comments, Problems or Parts Orders
Call NorthStar Product Support 1-800-270-0810

Parts Breakdown – Exploded View 110800, 110900, 1131 – Rev E.1

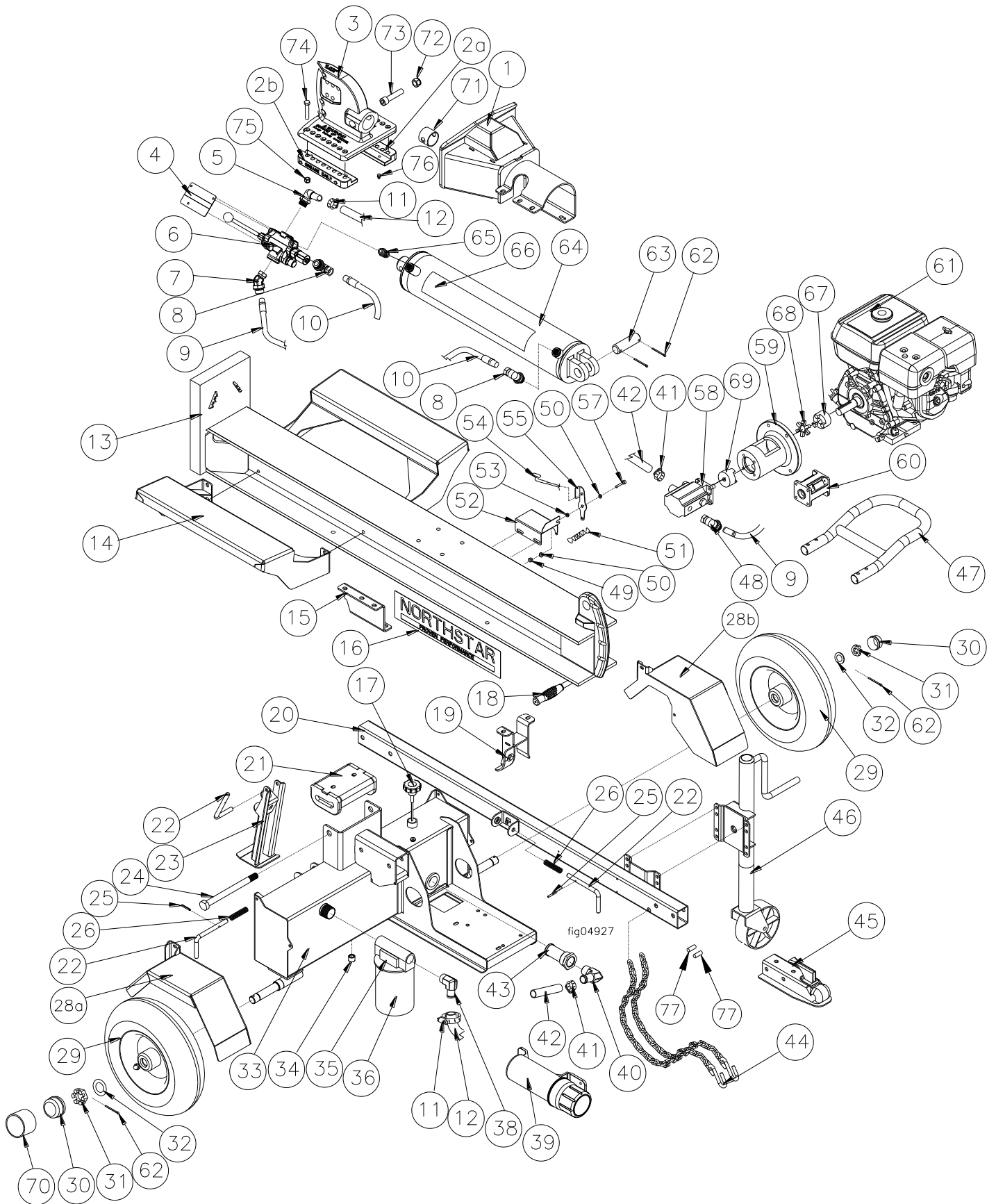

Parts Breakdown – Exploded View 110800, 110900, 1131 – Rev E.1

Ref#	Part#	Desc	Qty	Model
1	790445	Dislodger/Log Stripper	1	110800
	790446			110900
	790447			1131
2a	783968	Wedge Keeper, Right	1	All
2b	783969	Wedge Keeper, Left	1	All
3	788263	Wedge	1	All
4	791187	Valve Plate	1	All
5	778642	90 O-ring x Barb, 12-12	1	110800 110900
	789051	90 12MOR x 1.25" HB	1	1131
6	791868	Hyd Control Valve	1	110800 110900
	791869	Hyd Control Valve	1	1131
7	791219	12 MOR-8 FP x 45 Forged	1	All
8	778827	8MOR x 8 FP x 90 Forged	2	All
9	790489	High Pressure Hose ½" ID x 56" Long	1	All
10	778619	High Pressure Hose ½" ID x 21.75 Long	1	All
11	17141	Hose Clamp, 3/4"	2	110800
	777835	Hose Clamp 13/16"-1-3/4"	2	110900 1131
12	790699	Hose, 3/4" ID x 65"	1	110800 110900
	790486	Hose, 1.25" ID x 69"	1	1131
13	787833	Beam	1	All
14	790562	Log Cradle	2	All
15	790444	Gusset	1	All
16	790776	Decal, NorthStar Branding	2	All
17	784470	Breather Cap/Oil Dipstick	1	All
18	778459	Hand Grip	1	All
19	790548	Horizontal Beam Lock	1	All
20	790473	Towbar	1	All
21	788343	Bracket, Pivot	1	All
22	788243	Latch Rod	3	All
23	790926	Out Rigger Leg	1	All
24	790746	Pivot Pin	1	All
25	788244	Latch Rod Pin	3	All
26	788245	Latch Spring	3	All
28a	790930	Fender, Right	1	All
28b	790931	Fender, Left	1	All
29	790350	Tire	2	All
30	124A	Dust Cap	2	All
31	777124	Spindle Castle Nut	2	All
32	778844	Axle Stub Washer	2	All
33	788349	Hydraulic Tank	1	110800 110900
	788350	Hydraulic Tank	1	1131

Ref#	Part#	Desc	Qty	Model	
34	790064	1/2" Magnetic Hex Plug	1	All	
35	791244	Filter Head-Sm	1	110800 110900	
	791245	Filter Head-Lg		1131	
36	791247	Return Line Filter-Sm	1	110800 110900	
	791248	Return Line Filter-Lg		1131	
38	778829	MNPT x HB Elbow	1	110800 110900	
	790487	1.25" NPT x 1.25" HB	1	1131	
39	788040	Manual Tube	1	All	
40	778829	MNPT x HB Elbow	1	110800	
	788504	1" NPT x 1" HB Elbow	1	110900 1131	
41	17141	Hose Clamp, 3/4"	2	110800 110900	
	777835	Hose Clamp, 13/16"-1-3/4"	2	1131	
42	790705	Low Pressure Hose ¾" ID x 14"	1	110800	
	791170	Low Pressure Hose 1" ID x 16"	1	110900	
	790483	Low Pressure Hose 1" ID x 17.5"	1	1131	
43	790265	Strainer 3/4" FPT x 1.5 MPT	1	110800	
	790470	Strainer 1" FPT x 1.5" MPT	1	110900 1131	
44	1130	Safety Chain	2	All	
45	778423	2" Ball/ Coupler	1	All	
46	791311	Jack	1	All	
47	790431	Engine Guard	1	All	
48	50RAS8	1/2" M x ½" F Rt Angle	1	All	
49	82065	#10-24 Nylon Nut	1	110900 1131	
50	31094	1/4" Brass Washer	2		
51	791408	Extension Spring	1		
52	788264	Throttle Bracket	1		
53	31095	1/4" Nylon Washer	1		
54	791382	Idle Control Cable	1		
55	778470	Idle Control Arm	1		
57	82058	1/4" x 1/4" Shoulder Bolt	1		
58	791862	Hydraulic Pump, 11 GPM	1		110800
	790677	Hydraulic Pump, 13 GPM	1		110900
	791861	Hydraulic Pump, 16 GPM	1	1131	
59	BR020110	Pump Bracket	1	1131	
60	3030	Pump Bracket	1	110800	
	BR020010		1	110900	
61	6059	Engine, Honda GX160	1	110800	
	6067	Engine, Honda GX200	1	110900	
	60968	Engine, Honda GX270	1	1131	
62	778674	Cotter Pin	4	All	
63	778592	Cylinder Pin	1	All	

Parts Breakdown – Exploded View 110800, 110900, 1131 – Rev E.1

64	790397	4" 24" Cylinder	1	110800
	790398	4.5" x 24" Cylinder		110900
	790399	5" x 24" Cylinder		1131
65	790488	8MOR x MOR Adjustable	1	All
66	790810	24 Ton Decal	2	110800
	790811	30 Ton Decal		110900
	790808	37 Ton Decal		1131
67	777910	Coupling 3/4"	1	110800 110900
	777911	Coupling 1"		1131
68	777912	Coupling Insert	1	110800 110900
	BR00600 1B	Coupling Insert	1	1131
69	777909	Coupling 1/2"	1	All
70	780599	Dust Cap Tool	1	All
71	790564	Adapter Sleeve	1	110800 110900
72	82332	5/8-11 Nylon Nut	1	All
73	82468	5/8-11 x 2-3/4 Socket Bolt	1	All
74	82467	7/16-14 x 2-1/4 Hex Bolt	16	All
75	82115	7/16-14 Nylon Nut	16	All
76	778873	8mm Grease Zerk	4	All
77	791545	Tow Bar Spacer	2	All

Summary of Important Safety information for Operation

WARNING

Carefully read and make sure you understand the following safety information before using the log splitter. Improper use or maintenance of the log splitter can result in serious injury to the operator or bystanders from moving parts that can crush or cut, flying objects, burns, fire or explosion, escaping high pressure hydraulic fluid, or carbon monoxide poisoning.

Introduction

- **Read Manual.** Read this operator's manual and the engine Owner's Manual completely before attempting to use the log splitter. Serious injury or death can result if safety instructions are not followed.
- **Instruct operators.** The log splitter owner should instruct all operators in safe log splitter operation.
- **Intended use.** Log splitters should only be used for splitting wood logs, lengthwise with the grain. Do not use for other purposes, as unforeseen hazards may result.

Prohibition Against Modifications

Never modify or alter the log splitter in any way. Modifications can create serious safety hazards and will void the warranty.

- **Attachments.** Never add attachments to the splitter, except for authorized accessories supplied by the manufacturer with instructions for safe installation and use.
- **Engine Speed.** The maximum engine speed is preset at a safe limit. Never attempt to modify the engine speed setting to run at a higher speed.
- **Fuel/Exhaust system.** NEVER modify or add to the exhaust system, fuel tanks, or fuel lines. Fire can result.
- **Remote Control.** NEVER attach a rope, cable, or other remote device to the splitting control.
- **Splitting Wedge.** NEVER attempt to change the height or speed of the splitting wedge.
- **Pressure Setting.** NEVER increase the pressure setting of the pump or control valve.

Operator Restrictions

- **Untrained Operators.** Do not allow anyone to operate the log splitter who has not read the owner's manual or been instructed on the safe use of the splitter.
- **Minimum Operator Age.** Never allow anyone under age 16 to operate the log splitter. Anyone 16 years of age and older must be trained and supervised by a trained adult.

Safety in Moving and Towing the Log Splitter

WARNING

The log splitter is very heavy. It can cause serious injury if it rolls out of control or tips over.

Follow the safety instructions below for safely moving the log splitter.

General safety while Moving

- **Horizontal position.** Make sure the log splitter is secured in the horizontal position before moving the log splitter. DO NOT move the log splitter when it is in the vertical position because it will be unstable and could tip.
- **Hills.** Do not move the log splitter up or down hills by hand – use a towing vehicle.
- **Engine off.** Never move the log splitter with its engine running.
- **No riding.** Never allow anyone to sit or ride on the log splitter.
- **No cargo.** Never transport cargo or wood on the log splitter.

Safety During Towing

- **Read instructions.** Review towing safety instructions in your towing vehicle manual.
- **Securely attached.** Be sure the log splitter is securely attached to the towing vehicle before towing.

Summary of Important Safety information for Operation

- **Tires.** Be sure the tires are fully inflated and in good repair before towing the log splitter. When adding air to the tires, do not over-inflate – serious injury could occur if tire explodes.
- **Added length.** Be aware of the added length of the splitter.
- **Speed Limit.** Never tow this log splitter over 45 mph. Faster speeds may result in loss of control.
- **Rough terrain.** Be extra cautious and drive slowly when traveling over rough terrain.
- **Under the influence.** Never tow this splitter while under the influence of alcohol, drugs, or medication.
- **On public roads.** If towing on a public road, make sure to comply with all local, state, and federal towing requirements. It is the sole responsibility of the purchaser to obtain licensing, trailer lights, safety chains or signage, as needed to comply.
- **Unattended.** Turn off the towing vehicle before leaving the splitter unattended.
- **Disconnect before operate.** Do not use the log splitter while it is connected to the towing vehicle.

Safety – Before Use

Read/instruct

- **Read manual.** Do not allow anyone to operate the log splitter who has not read the owner's manual or has not been instructed on the safe use of the splitter.
- **Review safety rules.** Before starting this log splitter, review the "Rules for Safe operation." Failure to follow these rules may result in serious injury to the operator or bystanders.
- **Know how to stop.** Be thoroughly familiar with all controls and proper use of the equipment. Know how to stop the splitter and relieve system pressures quickly if needed.

Personal protective equipment

- **Eye protection.** Always wear safety glasses or goggles when operating the machine. Pieces of log may fly out and serious eye injury can occur.
- **Boots.** Falling logs can crush feet. Always wear safety shoes or heavy boots when operating or helping to load logs.
- **Loose/dangling.** Loose or dangling apparel can become entangled in moving parts. Never wear jewelry or loose-fitting clothing.
- **Gloves.** Wear snug fitting gloves without drawstrings or loose cuffs.
- **Hearing Protection.** The use of earplugs or other hearing protection device is recommended.

Safety During Inspection/Maintenance

Always inspect your log splitter before each use, and repair as needed, to keep it in safe working condition:

- **Engine off.** Always make sure the engine is off before cleaning, repairing or adjusting the splitter, except as recommended by the manufacturer.
- **Engine debris.** Debris on a hot engine can be a fire hazard. With the engine off, clean debris and chaff from engine cylinder head, cylinder head fins, blower housing rotating screen, and muffler areas. Avoid contact with hot muffler.
- **Other debris.** Debris on moving parts can cause excess wear. With the splitter engine off, clear debris from moving parts.
- **Fuel tank / lines.** Before each use, check fuel tank and fuel lines for leaks. Any fuel leak is a fire hazard. Fix any fuel leaks before starting engine.
- **Mechanical parts.** Check to be sure that all nuts and bolts are tight to make sure the log splitter is in safe working condition.
- **Hydraulic system.** Check the hydraulic system (hoses, tubing, clamps/fittings, pump, and cylinder) carefully before each use. Do not operate the log splitter with frayed, kinked, cracked or damaged hydraulic hoses, fittings, or tubing, or if oily residue is observed on any of the components. High fluid pressures and temperatures are developed in the log splitter. Hydraulic fluid escaping through a pin hole sized opening can burn or puncture skin, resulting in wounds that could cause blood poisoning, infection, disability, gangrene, amputation, or death. Therefore, the following instructions should be heeded at all times when inspecting or servicing the hydraulic components of the log splitter:
 - Do not remove the hydraulic oil dipstick when the engine is running. Hot oil can escape causing severe burns. Allow log splitter to cool completely before removing hydraulic oil dipstick.
 - Do not adjust the pressure setting of the pump or valve.

Summary of Important Safety information for Operation

- o Do not check for leaks with your hand. Leaks can be located by holding a piece of cardboard or wood (at least two feet long) with your hand at one end and passing the other end over the suspected area (wear eye protection). Look for discoloration of the cardboard or wood.
- o Stop the engine, disconnect the spark plug, and move all control valve handles back and forth to relieve pressure before changing or adjusting hydraulic system components such as hoses, tubing, fittings or other components.
- o If injured by escaping fluid, no matter how small the wound is, see a doctor at once. A typical injection injury may be a small puncture wound that does not look serious. However, severe infection or reaction can result if proper medical treatment is not administered immediately by a doctor who is familiar with injection injuries.
- **Spark arrestor muffler.** If the engine is equipped with a spark arrestor muffler, clean and inspect it regularly (follow manufacturer's service instructions). Replace if damaged.
- **Tires.** Be sure tires are fully inflated and in good repair before towing the splitter. When adding air to tires, do not over-inflate -- serious injury could occur if tire explodes.
- **Guards / shields.** Make sure all guards and shields are replaced after servicing the log splitter.
- **Replacement parts.** If a part needs replacement, only use parts that meet the manufacturer's specifications. Replacement parts that do not meet specifications may result in a safety hazard or poor operation of the log splitter.

Safety During Fueling

- **Gasoline is highly flammable and explosive.** You can be burned or seriously injured when handling fuel. Use extreme care when handling gasoline:
- **Fuel outdoors.** Fill fuel tank outdoors – never indoors. Gasoline vapors can ignite if they collect inside an enclosure. Explosion can result.
- **Use approved container.** Never pump fuel directly into engine at gas station. Static charge can build and ignite fuel. Use an UL approved fuel container to transfer gas to the engine.
- **Running / hot engine.** A running engine is hot enough to ignite fuel. Never add fuel or remove gas cap if engine is running or still hot. Stop the engine and allow to cool at least two minutes before adding fuel.
- **Heat / flames / sparks.** Stay away from sources of heat, flame, or sparks while adding fuel.
- **Don't overfill.** DO NOT overfill the gas tank. Allow at least 1/2" of empty space below the fill neck to allow for fuel expansion.
- **Replace cap.** Replace gas cap securely before starting engine.
- **Spills.** Clean up fuel spills immediately. Move log splitter away from spilled fuel on the ground. Wipe fuel off engine and wait 5 minutes for excess fuel to evaporate before starting engine. Gas soaked rags should be disposed of properly.
- **On skin / clothes.** If gasoline is spilled on your skin or clothes, change clothes and wash skin immediately.
- **Gasoline storage.** Store gasoline in a cool, dry place in an UL approved, tightly sealed container.

Safety in Work Site Selection

- **Spark arrestor.** If your splitter will be used near any unimproved forest, brush, or grassy covered land, then engine should be equipped with a spark arrestor. See the "Specifications" section of this manual to determine if your splitter already has a spark arrestor. Make sure you comply with applicable local, state and federal codes.
- **Hot exhaust.** Hot exhaust fumes from engine can cause fire. Position muffler at least 7' from combustible objects during operation.
- **Fire extinguisher.** Have a Class B fire extinguisher available as a precautionary measure when operating the log splitter in dry areas.
- **Level, dry surface.** To prevent accidental falls and equipment tip over, make sure the splitter is situated on a dry, level surface with good footing. Stay clear of areas with mud, ice, tall grass, weeds, brush, or snow.
- **Block wheels.** Always block the wheels to prevent unintended movement of the log splitter.
- **Carbon monoxide.** The running engine gives off carbon monoxide, a poisonous gas that can kill you. You CANNOT smell it, see it, or taste it. ONLY run log splitter OUTDOORS and away from air intakes. NEVER run log splitter inside homes, garages, sheds, or other semi-enclosed spaces. These spaces can trap poisonous gases, EVEN if you run a fan or open windows. If you start to feel sick, dizzy, or weak while using the log splitter, shut off the engine and get to fresh air RIGHT AWAY. See a doctor. You may have carbon monoxide poisoning.

Summary of Important Safety information for Operation

Safety – During Use General Safety During Use

⚠ WARNING: Before starting this log splitter, review the following rules for safe operation. Failure to follow these rules may result in serious injury to the operator or bystanders.

- **Safety equipment / controls.** Always operate the log splitter with all safety equipment in place and in good working order, and all controls properly adjusted for safe operation.
- **Operating speed.** Always operate the log splitter at the manufacturer's recommended speed. The maximum speed of the engine, pump and wedge are preset within safe limits.
- **Know how to stop.** Be thoroughly familiar with all controls and with the proper use of the equipment. Know how to stop the log splitter and relieve system pressures quickly if needed.
- **Daylight only.** Only use the log splitter in daylight so you can see what you are doing.
- **Smoking / sparks.** Never smoke while operating the log splitter, and never operate near sources of sparks or flames.
- **Hot muffler.** If you are starting a warm engine, stay clear of muffler. It may still be hot enough to burn you.
- **Unattended.** Never leave the machine unattended while the engine is running.
- **Under the influence.** Never operate, or let anyone else operate, the log splitter while under the influence of alcohol, drugs, or medication.
- **Adjusting / repairing.** Always make sure the engine is off before cleaning, repairing or adjusting the splitter, except as recommended by the manufacturer. In addition, disconnect the spark plug and move all control handles back and forth to relieve system pressure *before changing or adjusting hydraulic system components* such as hoses, tubing, fittings or other components.
- **Carbon monoxide.** The running engine gives off carbon monoxide, a poisonous gas that can kill you. You CANNOT smell it, see it, or taste it. If you start to feel sick, dizzy, or weak while using the log splitter, shut off the engine and get to fresh air RIGHT AWAY. See a doctor. You may have carbon monoxide poisoning.
- **Other exhaust dangers.** Engine exhaust, some of its constituents, and certain vehicle components contain or emit chemicals known to the State of California to cause cancer, birth defects, or other reproductive harm. Avoid inhalation of exhaust.

Safety in Loading, Operating, and Unloading

- **Square log ends.** Logs that are not cut square can slide out while splitting and become a safety hazard or cause excessive force to log splitter components. Use a chainsaw to cut logs square on each end before attempting to split them.
- **Single log.** Never attempt to split more than one log at a time. Pieces of log can unexpectedly be thrown from the machine causing serious injury.
- **Split along grain.** Do not use the log splitter to split logs across the grain. Doing so will damage the log splitter and could also cause pieces of log to be thrown, injuring the operator or bystanders.
- **Forked logs.** Splitting forked logs can cause damage the log splitter. Trim the forked log with a chain saw prior to splitting the log.
- **Keep hands clear.** ALWAYS keep hands and feet away from the endplate, wedge, and partially split logs while loading, operating and unloading the log splitter.
- **Operator position.** ALWAYS operate the log splitter from the manufacturer's indicated OPERATOR POSITION. Other positions are unsafe because they can increase the risk of injury from crushing, cutting, flying objects, or burns.
- **Straddling / reaching across.** Never straddle, reach across, or step over the beam while the engine is running and the log splitter is in the horizontal position. You could trip, actuate the controls, and get seriously injured.
- **Second person.** Many accidents occur when there is more than one person involved in loading and operating the log splitter. Only one person should operate the controls. *If a second person is assisting in loading logs, the operator must NEVER actuate the Split Control Lever until the assistant and all bystanders are at least 10 feet away. NEVER allow an assistant to hold the log in place while the operator actuates the Split Control Lever.*

Summary of Important Safety information for Operation

Loading/Unloading

- **Unsplit log pile.** Do not pile logs to be split in a place that will make you reach across the log splitter in order to load them.
- **Hold bark side.** Hold the bark side of logs when loading or positioning, never the ends. Never place your hands or any part of your body between a log and any part of the log splitter.
- **NOTE for vertical position loading:** Place the log on the endplate and turn it until it leans against the beam and is stable. If the log is too big or oddly shaped, stabilize the log with wooden shims between the log and endplate or ground. DO NOT use your leg or knee to stabilize the log. NEVER stabilize the log by placing your hand on top of the log.
- **Wedge moving.** NEVER load or unload logs while the wedge is moving.
- **Cracks.** Cracks in logs can close quickly and pinch fingers. Keep fingers away from any cracks that open in partially split logs.
- **Split log pile.** Move each log away from log splitter after it is split. Split logs left near the log splitter are a trip hazard.
- **Remove hands.** Remove both hands from log before activating Split Control Lever.
- **Hand activate.** Use only your hand to operate the Split Control Lever. Never use any other body part, or a rope, cable, or other remote device to actuate the control.
- **Returning wedge.** Once the control valve is actuated in the return direction, the wedge is designed to keep returning by itself completely and then stop automatically. Stay clear while the wedge is returning. It is still powerful enough on the return stroke to cause serious injury.
- **Log stuck on wedge.** If a log does not split completely and becomes stuck on the wedge, follow the instructions below to remove the log. A log can become stuck to the wedge if the wedge becomes embedded in the log and the log doesn't split and separate. This can happen if the log is too stringy or tough to split completely. A stuck log will move back with the wedge on the initial attempt to retract the wedge. If this happens, retract the wedge completely to allow the splitter to strip the log from the wedge. Keep hands clear of log and wedge while wedge is retracting.
 - **⚠WARNING:** NEVER attempt to remove a stuck log by:
 - Modifying the splitter.
 - Adding attachments to the splitter.

Personal injury could result from log or metal pieces flying out at high speed toward the operator or bystanders, or the splitter could become damaged.

- **Changing splitting position.** Do not change splitting positions (horizontal/vertical) with the engine running. You may contact the muffler and receive serious burns. Be careful to avoid contact with hot muffler even after the engine is turned off.
- **Refueling.** Never refuel the engine until it has cooled at least two minutes.

Safety – After use

- **Return to horizontal.** If in the vertical position, turn off engine and return log splitter to the horizontal position for greater stability and to prepare for transportation. Avoid contact with hot muffler.
- **Remove engine debris.** Debris on a hot engine can be a fire hazard. With the engine off, clean debris and chaff from engine cylinder head, cylinder head fins, blower housing rotating screen, and muffler areas. Avoid contact with hot muffler.
- **Let engine cool before storing.** Let engine cool for at least five minutes before storing. A hot engine can be a fire hazard.
- **Storage location.** Store the log splitter in a location away from sources of heat, open flames, sparks or pilot lights – such as water heaters, space heaters, furnaces, clothes dryers, or other gas appliances. Even if the log splitter's gas tank is empty, residual gasoline vapors could ignite.
- **Gasoline storage.** Store extra gasoline in a cool, dry place in an UL approved, tightly sealed container. Gasoline vapors can ignite if they collect inside an enclosure.
- **Periodic maintenance.** Perform periodic maintenance as directed in this manual to keep the log splitter in safe working condition.

Assembly Instructions

Remove all components from the shipping container. Using this manual, identify and sort components as necessary.

Closely inspect all log splitter components.

If you have missing or damaged components, please contact Product Support at 1-800-270-0810.

Find a work space that is large enough to maneuver log splitter once completely assembled. Assemble log splitter on solid and level ground.

CAUTION! Heavy lifting required. Some of the components in these assembly instructions are heavy and cannot be lifted by one person safely. Please plan on assembling this product when another person can be available to help out.

Tools needed: Adjustable wrenches, Torque Wrench, Soft Faced Mallet, Flat Blade Screw Driver, Allen Wrench

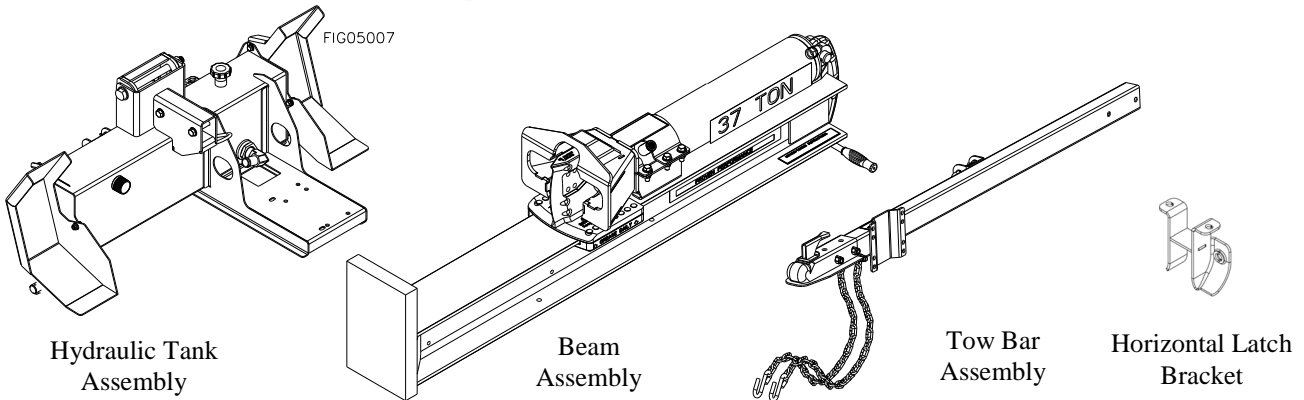

Contents below are shrink-wrapped together and packaged inside log splitter crate.

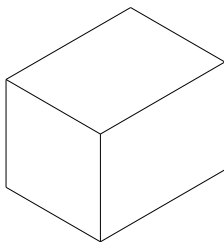
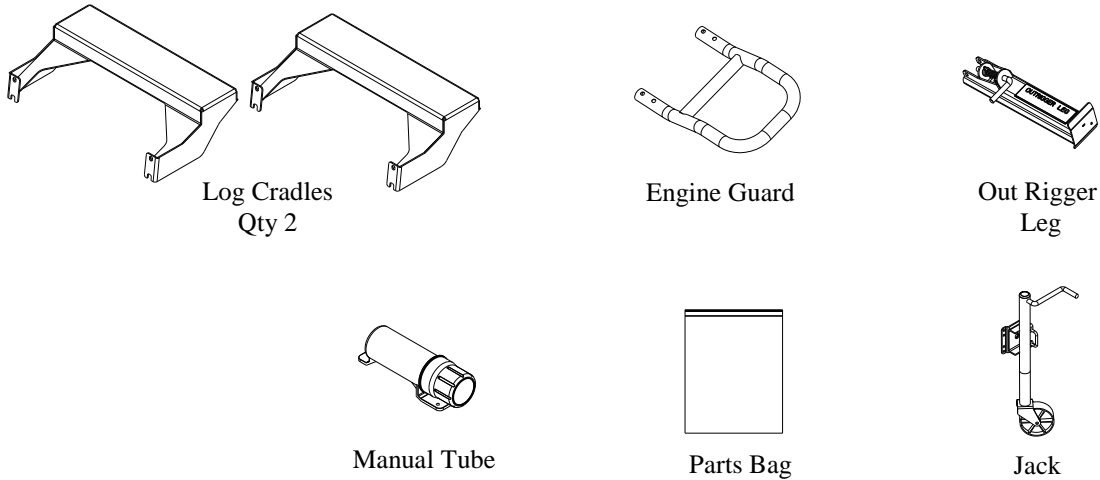

Box may come attached to log splitter crate or shipped separately.

Engine Pump
Combo Box

Wheels are shrink-wrapped separately to the ends of beam on log splitter crate.

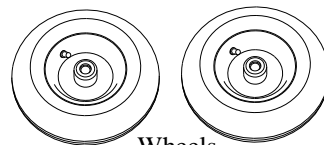

Wheels
Qty 2

Assembly Instructions

Parts Bag:

FIG05005

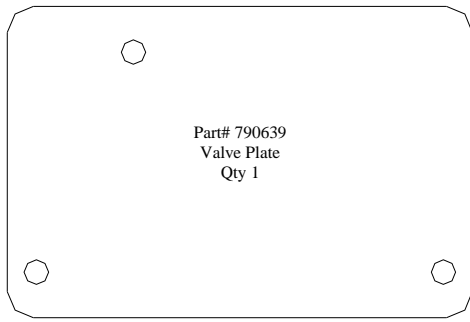

Part# 790639
Valve Plate
Qty 1

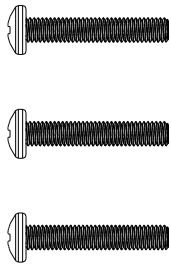

Valve Plate
Part# 82562
M6-1.0 x 35mm PHCS, Zinc
Qty 3



Valve Plate
Part# 82563
M6-1.0 Nylon Insert Locknut
Qty 3

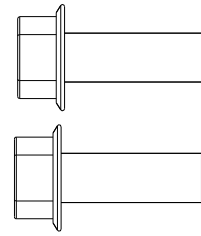

Horizontal Latch to Beam
Part# 82551
M12-1.75 x 35 HHFS GR5Z
Qty 2

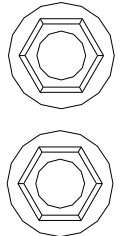

Horizontal Latch to Beam
Part# 82273
M12-1.75 Ser Flange Nut
Qty 2

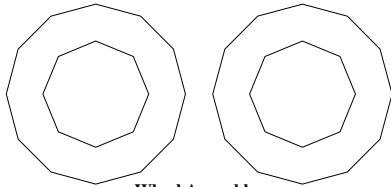

Wheel Assembly
Part# 778844
Axle Stub Washer
Qty 2

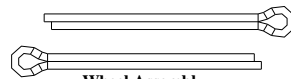

Wheel Assembly
Part# 778674
Cotter Pin, 1/8" x 2"
Qty 2

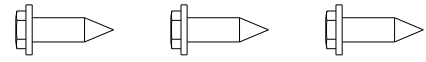

Manual Tube
Part# 82529
M6 x 20mm Self Tapping Screw
Qty 3

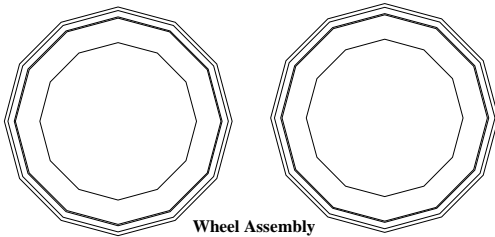

Wheel Assembly
Part# 124A
Dust Cap
Qty 2

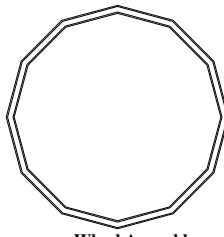

Wheel Assembly
Part# 780599
Dust Cap Tool
Qty 1

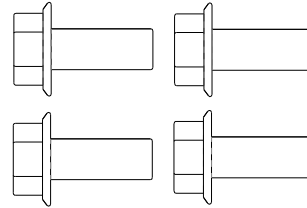

Jack to Tow Bar
Part# 82262
M10-1.5 x 25 HHFS
Qty 4

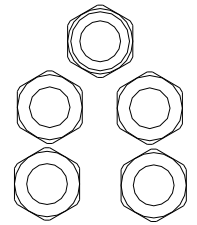

Jack to Tow Bar, Qty 4
Out Rigger to Tank, Qty 1
Part# 82270
M10-1.5 Nylon Insert Nut

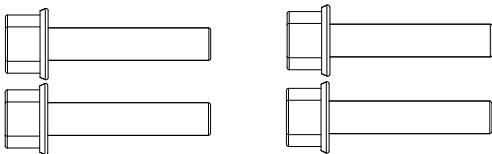

Log Cradles to Beam
Part# 82545
M8-1.25 x 30 HHFS GR5Z Bolt
Qty 4

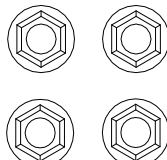

Log Cradles to Beam
Part# 82281
M8-1.25 Ser Flange Nut
Qty 4



Out Rigger to Tank
Part# 82201
M10 Flat Washer
Qty 1

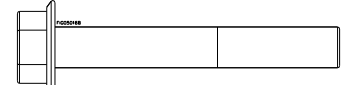

Out Rigger to Tank
Part# 82574
M10-1.5 x 70 HHSF Bolt
Qty 1



Throttle Cable to Beam
Part# 82545
M8-1.25 x 30 HHFS GR5Z Bolt
Qty 2

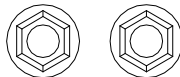

Engine to Engine Mount on Tank
Part# 82281
M8-1.25 Ser Flange Nut
Qty 2

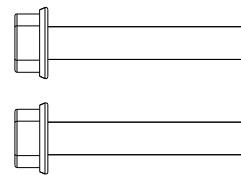

Engine Guard to Beam
Part# 82565
M8-1.25 x 50mm HHCS GR5
Qty 4

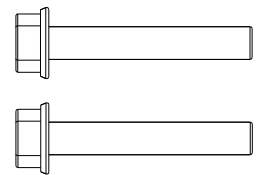

Engine Guard to Beam
Part# 777495
M8-1.25 Nyloc Nut
Qty 4

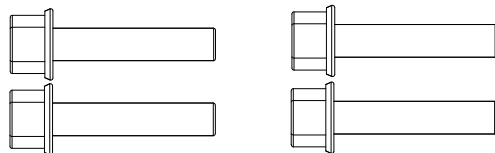

Engine to Engine Mount on Tank
Part# 82280
M8-1.25 x 40mm HHFS
Qty 4

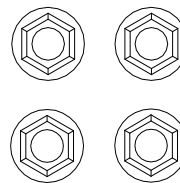

Engine to Engine Mount on Tank
Part# 82281
M8-1.25 Ser Flange Nut
Qty 4



Throttle Cable Clamp to
Engine Mount
Part# 82281
M8-1.25 Nut
Qty 1

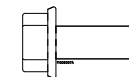

Throttle Cable Clamp to
Engine Mount
Part # 82545
M8-1.25 x 30 Bolt
Qty 1

Assembly Instructions

Parts Bag Continued:

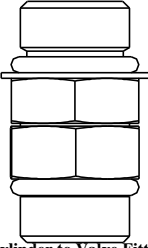
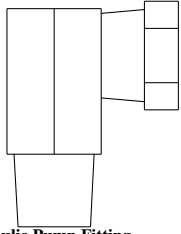
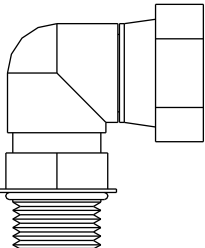
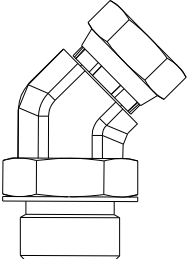
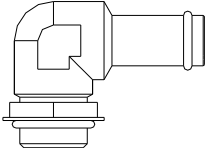
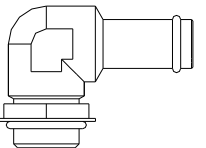
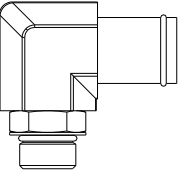
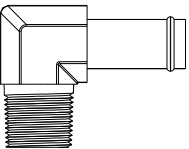
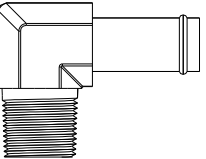
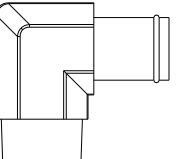
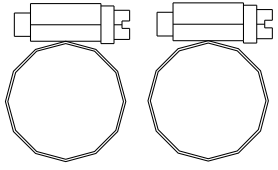
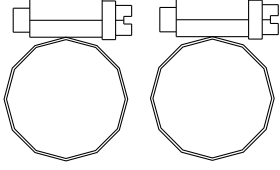
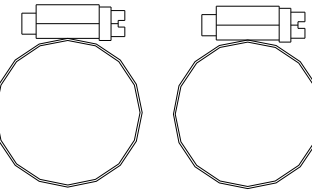
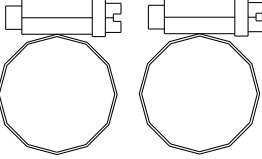
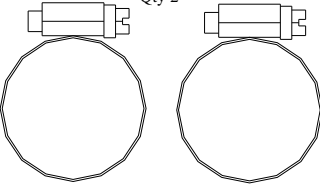
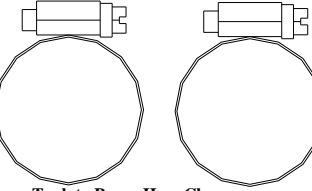
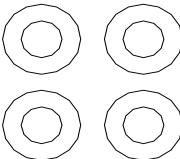
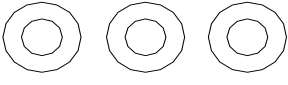
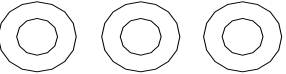
110800, 110900, & 1131		
 <p>Cylinder to Valve Fitting Part# 790488 8MOR x 8 MOR Adj Fitting Qty 1</p>	 <p>Hydraulic Pump Fitting Part# 50RASS 1/2" M x 1/2" F Rt Angle Qty 1</p>	 <p>Valve to Cylinder Fitting Part# 778827 O-Ring x FNPT Swivel Elbow, 8-8 Qty 1</p>
 <p>Valve to Hydraulic Pump Fitting Part# 791219 12 MOR- 8 FP x 45 Forged Qty 1</p>		
110800 Only	11090 Only	1131 Only
 <p>Valve to Hydraulic Filter Fitting Part# 778642 90° O-Ring Boss x 3/4" Hose Barb Qty 1</p>	 <p>Valve to Hydraulic Filter Fitting Part# 778642 90° O-Ring Boss x 3/4" Hose Barb Qty 1</p>	 <p>Valve to Hydraulic Filter Fitting Part# 789051 12 MOR x 1.25 HB Qty 1</p>
 <p>Return Line Filter Fitting Part# 778829 MNPT x Hose Barb Elbow, 12-12 Qty 1</p>	 <p>Return Line Filter Fitting Part# 778829 MNPT x Hose Barb Elbow, 12-12 Qty 1</p>	 <p>Return Line Filter Fitting Part# 790487 1.25" MPT x 1.25" HB Elbow Qty 1</p>
 <p>Filter to Valve Hose Clamps Part# 17141 3/4" Hose Clamp Qty 4</p>	 <p>Filter to Valve Hose Clamps Part# 17141 3/4" Hose Clamp Qty 2</p>	 <p>Filter to Valve Hose Clamps Part# 17141 3/4" Hose Clamp Qty 4</p>
 <p>Tank to Pump Hose Clamps Part# 17141 3/4" Hose Clamp Qty 4</p>	 <p>Tank to Pump Hose Clamps Part# 777935 13/16" to 1-3/4" Hose Clamp Qty 2</p>	 <p>Tank to Pump Hose Clamps Part# 777935 13/16" to 1-3/4" Hose Clamp Qty 4</p>
 <p>Engine Guard to Beam Part# 777496 M8 Flat Washer Qty 4</p>	 <p>Engine Guard to Beam Part# 777496 M8 Flat Washer Qty 3</p>	 <p>Engine Guard to Beam Part# 777496 M8 Flat Washer Qty 3</p>

Assembly Instructions

Engine Pump Combo Box:

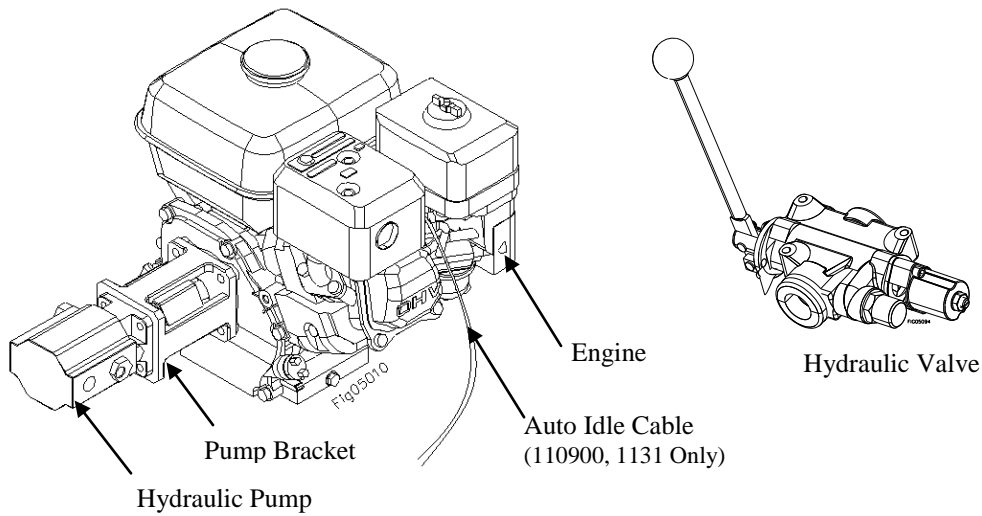

110800, 110900, 1131

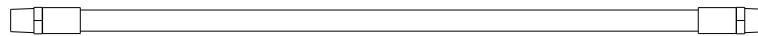

Valve to Cylinder Hose

Part# 778619

High Pressure Hose, 21.75" x 1/2" ID with
1/2" Male NPT fittings

Qty 1



Valve to Hydraulic Pump

Part# 790489

High Pressure Hose, 56" x 1/2" ID with
1/2" Male NPT fittings

Qty 1

110800 Only



Valve to Return Line Filter Hose

Part# 790699

Return Line Hose, 65" x 3/4" ID

Qty 1

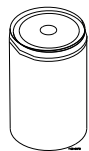

Return Line Filter

Part# 791247

Qty 1

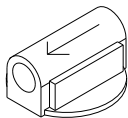

Filter Head

Part# 791244

Qty 1



Tank to Hydraulic Pump Hose

Part# 790705

Suction Hose, 14" x 3/4" ID

Qty 1

Assembly Instructions

110900 Only

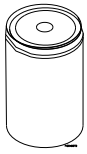

Return Line Filter
Part# 791247
Qty 1

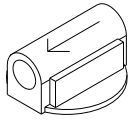

Filter Head
Part# 791244
Qty 1

Valve to Return Line Filter Hose
Part# 790699
Return Line Hose, 65" x 3/4" ID
Qty 1

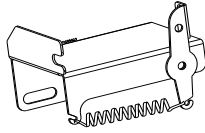

Throttle Bracket Assembly
See parts explosion

Tank to Hydraulic Pump Hose
Part# 791170
Suction Hose, 16" x 1" ID
Qty 1

1131 Only

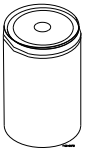

Return Line Filter
Part# 791248
Qty 1

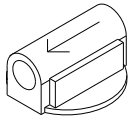

Filter Head
Part# 791245
Qty 1

Valve to Return Line Filter Hose
Part# 790486
Return Line Hose, 69" x 1/1/4" ID
Qty 1

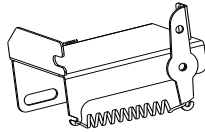

Throttle Bracket Assembly
See parts explosion

Tank to Hydraulic Pump Hose
Part# 790483
Suction Hose, 17.5" x 1" ID
Qty 1

Owner's Manual Bag:

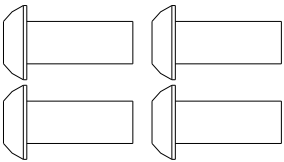

Fender to Tank
Part# 82596
M8-1.25 x 20mm BHCS
Qty 4

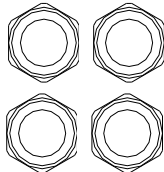

Fender to Tank
Part# 777495
M8-1.25 Nyloc Nut
Qty 4



Owner's Manual

Assembly Instructions

Step 1 – Fender to Tank Assembly

- Set hydraulic tank assembly on level surface.
- Detach left and right fenders from hydraulic tank assembly after unpacking. Discard bolts, washers, and nuts.
- Left and right fenders will be installed on the opposite side as delivered in the packaging.
- Align left and right fenders to hydraulic tank assembly as shown below.
- Insert bolts and secure with nuts.
- Torque to 21ft.-lb.

Tools Needed

- 5mm Allen Wrench
- Torque Wrench

Fasteners Needed (Located in Owner's Manual Bag):

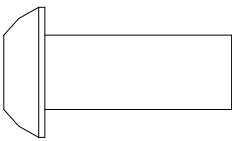

Fender to Tank
Button Head Cap Screw
Qty 4

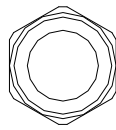

Fender to Tank
Nyloc Nut
Qty 4

Pictured below is the hydraulic tank assembly after unpacking from crate.
Remove bolts as shown.

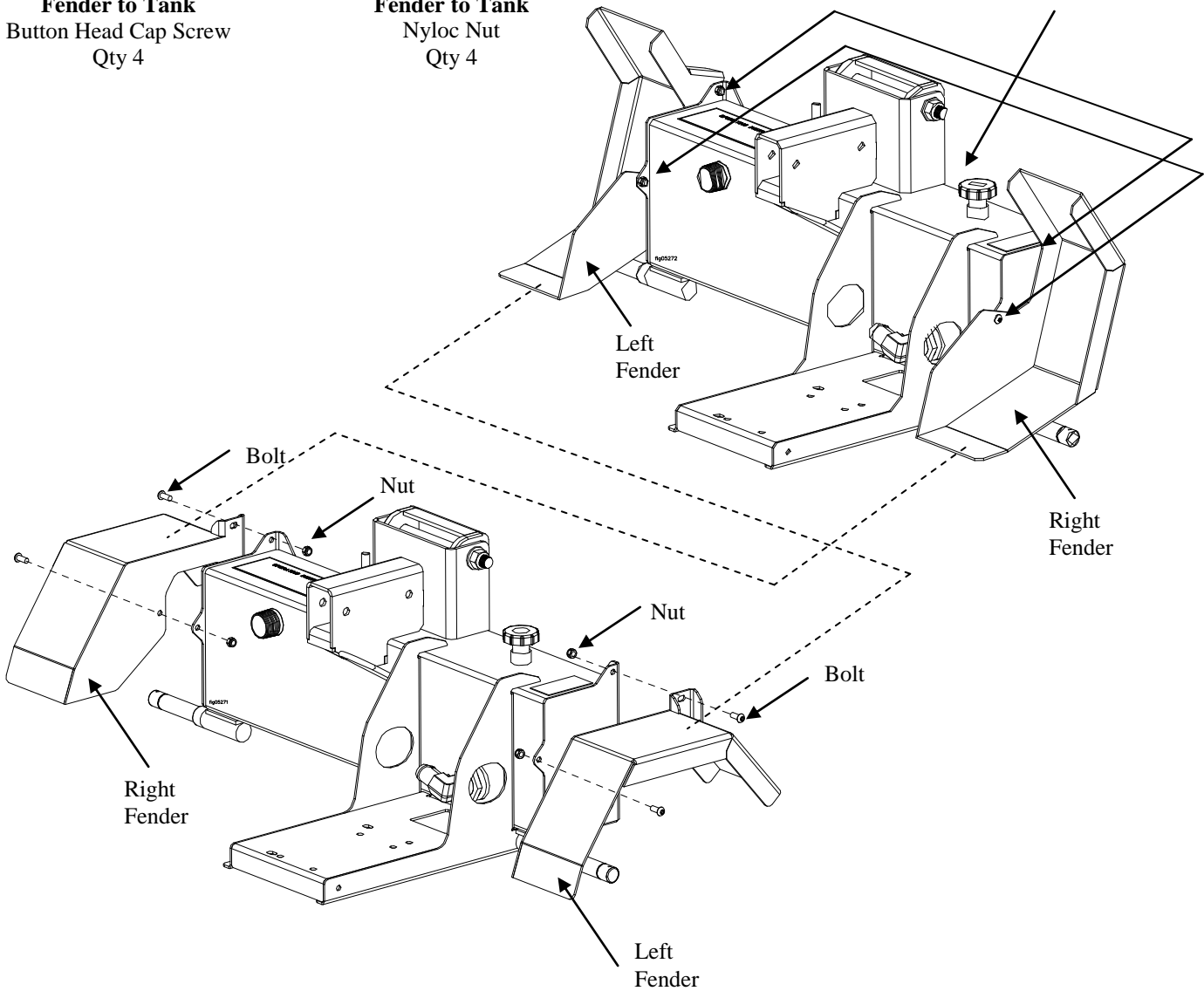

Assembly Instructions

Step 2 – Tire to Tank Assembly

NOTE: Axle nuts are installed (hand tight only) on axles. Remove from wheel prior to beginning this step. They will be re-installed.

- Slide tire onto axle with valve stem facing out.
- Slide wheel washer up against the wheel bearing.
- Thread axle nut onto axle.
- Using a torque wrench, tighten the axle nut to 30-40 ft.- lbs. Turn hub to ensure proper bearing seating.
- Loosen the axle nut until loose enough to turn the axle nut with your fingers.
- Re-tighten the axle nut until finger tight.
- Insert cotter pin through hole in axle nut and axle. Bend and spread prongs in opposite directions so the axle nut will not come off (make sure the tire spins freely).

Tools Needed

- Pliers
- Torque Wrench

Fasteners Needed from Parts Bag (Axle Nuts Located on Tank Assembly):

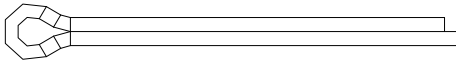

Cotter Pin
Qty 2

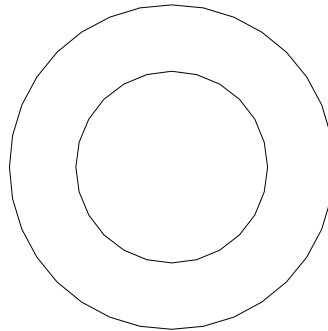

Wheel Washer
Qty 2

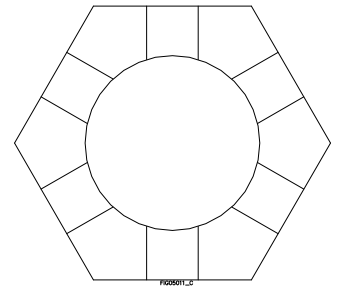

1" Axle Nut
Qty 2

*Partially Installed on Wheel
Not found in Parts Bag

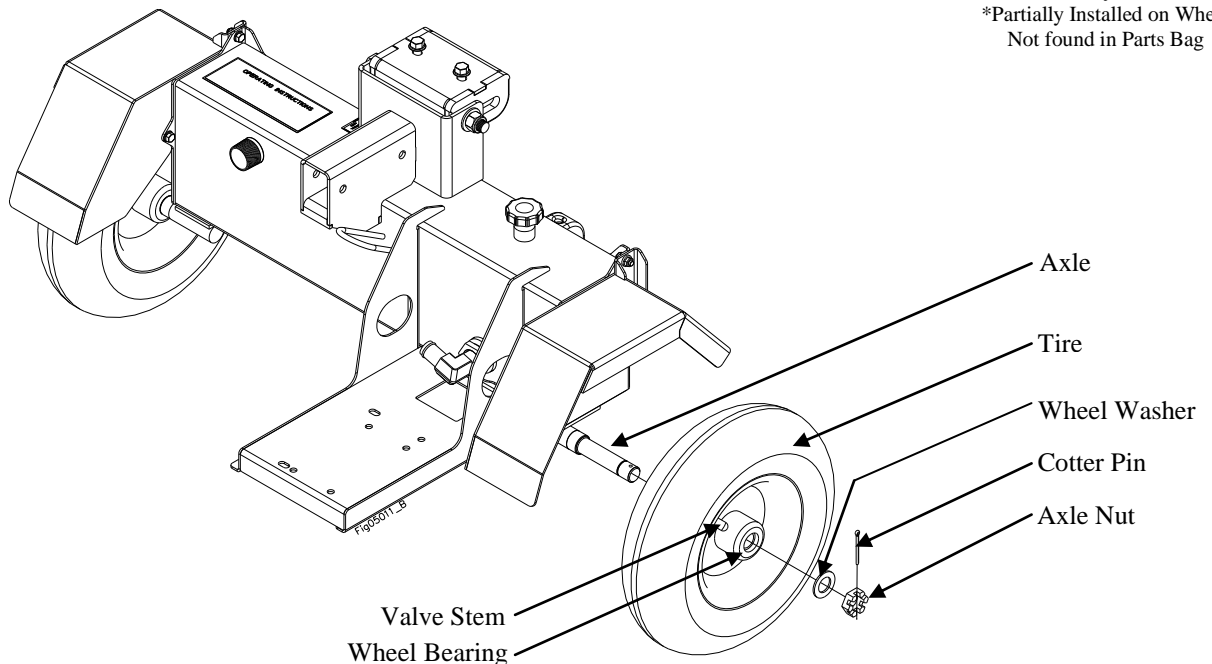

Assembly Instructions

Step 3 – Wheel Assembly

- Align the dust cap against the wheel hub.
- Position the dust cap tool evenly onto the surface of the dust cap.
- Place a piece of wood over the dust cap tool.
- Using a soft faced mallet tap the piece of wood against the dust cap tool to install dust cap onto the wheel hub.
- Repeat for the other wheel. Discard hub cap tool.

Tools Needed

- Soft Faced Mallet

Fasteners Needed from Parts Bag:

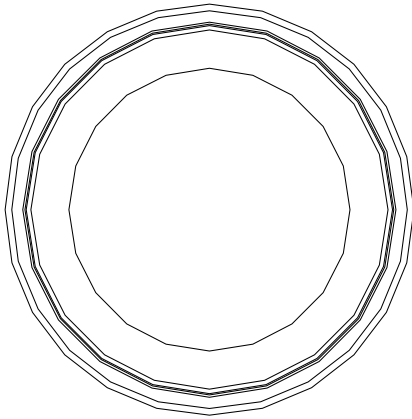

Dust Cap
Qty 2

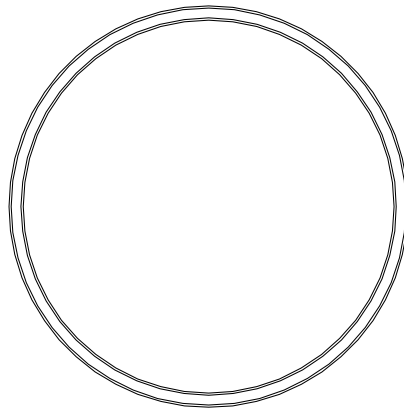

Dust Cap Tool
Qty 1

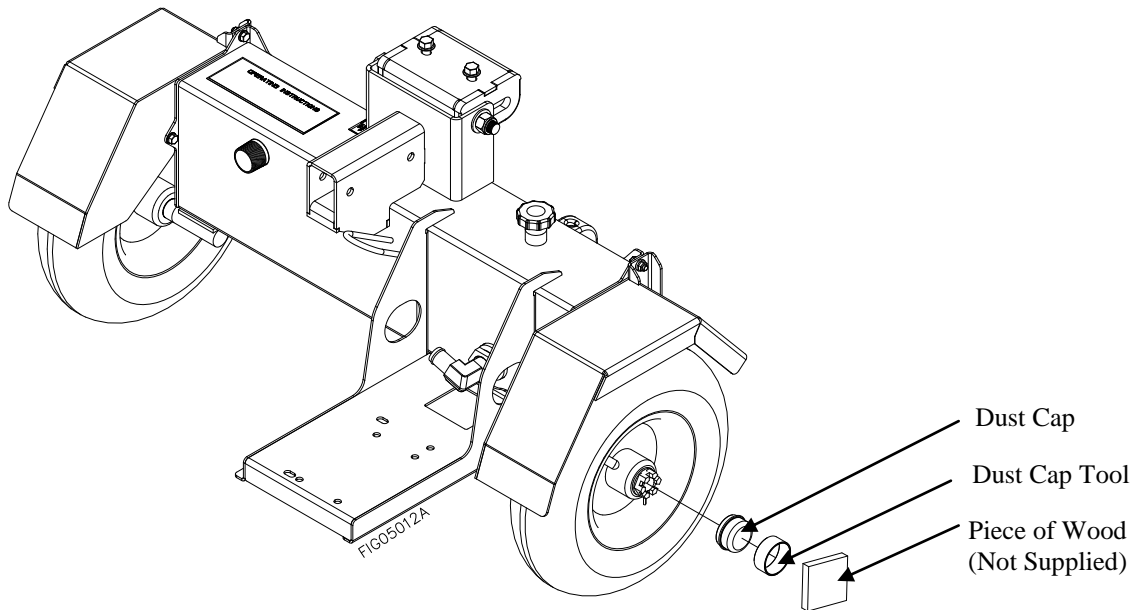

Assembly Instructions

Step 4 – Tow Bar to Tank

NOTE: *Nut and bolt are installed (hand tight only) on tow bar mount for packaging purposes. Remove nut and bolt prior to beginning this step. They will be re-installed.*

- Align holes on the tow bar to the tow bar mount on the hydraulic tank assembly.
- Re-install (2) bolts and (2) nuts, and tighten with wrench.
- Torque to 71 ft.-lb.

Tools Needed

- 18mm Wrench (2 Needed)
- Torque Wrench

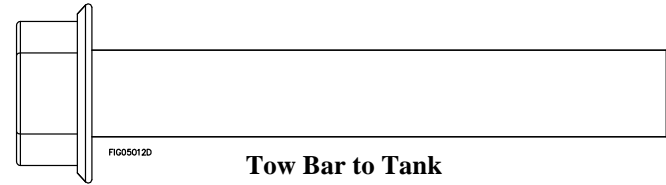

Tow Bar to Tank
Flange Bolt
Qty 2

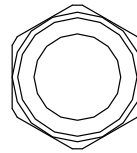

Tow Bar to Tank
Nyloc Nut
Qty 2

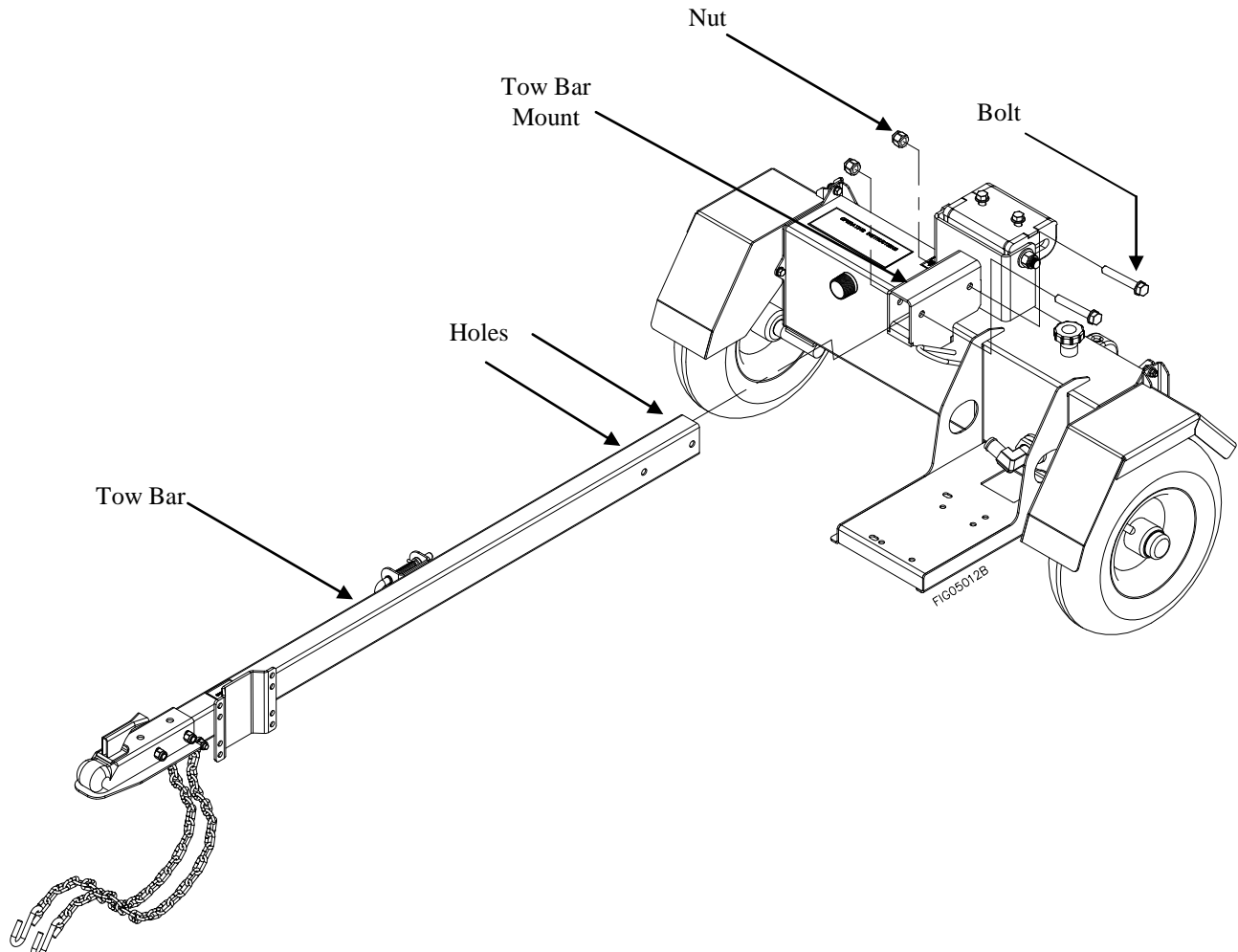

Assembly Instructions

Step 5 – Jack to Jack Mount/Tow Bar

- Connect jack to jack mount located on the front end of the tow bar.
- Align jack bracket to jack mount on tow bar. Insert (4) bolts and thread on (4) locknuts.
- Torque to 41 ft.-lb.

Tools Needed

- 15mm Wrench
- 16mm Wrench
- Torque Wrench

Fasteners Needed from Parts Bag:

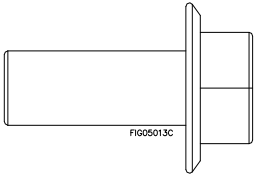

Jack to Tow Bar
Flange Bolt
Qty 4

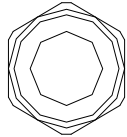

Jack to Tow Bar
Nyloc Nut
Qty 4

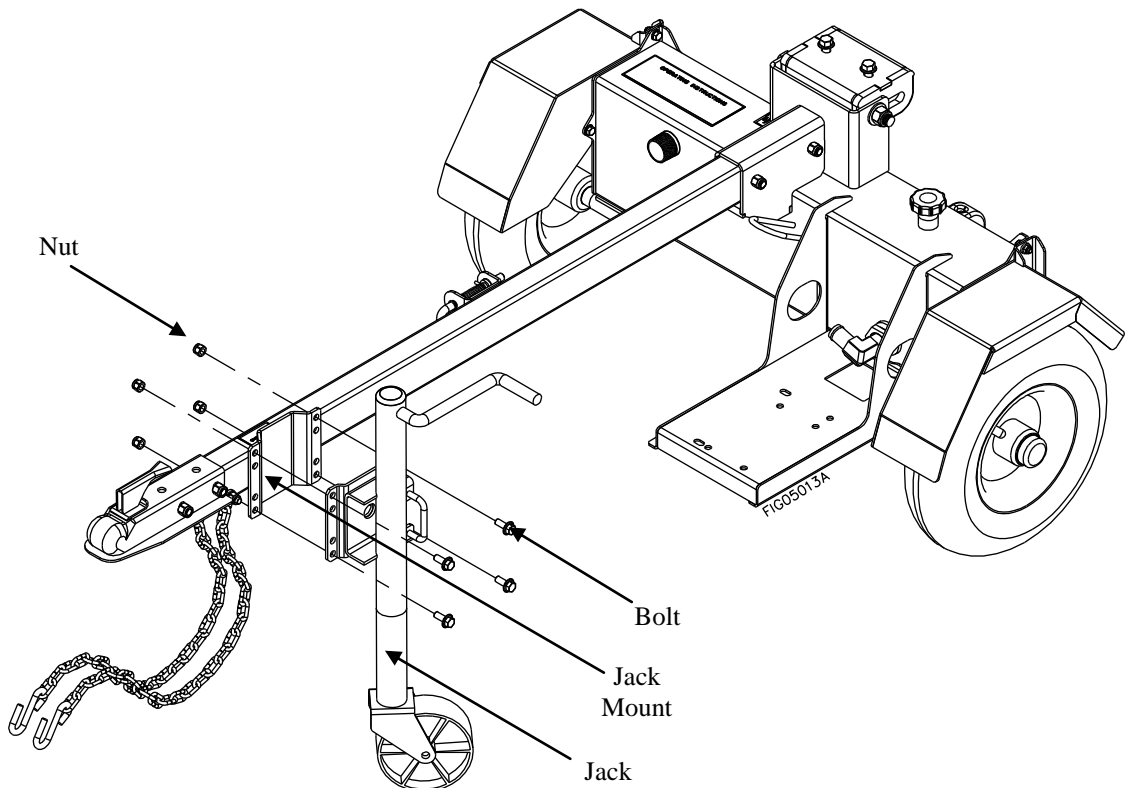

Assembly Instructions

Step 6 – Suction Hose to Hydraulic Tank

- Locate the shortest piece of suction hose and the appropriate sized hose clamp as shown below.
- Slide one end of the suction hose thru the inside hole of the engine mount bracket.
- Loosen hose clamp as necessary. Slide hose clamp onto end of suction hose and push hose onto elbow.
- Secure and tighten hose clamp around the suction hose and elbow. Torque to 78 in.-lb.
- Hose clamp must have a tight seal to prevent hydraulic oil from leaking.
- Allow suction hose to hang loose until further direction.

Tools Needed

- Flat Blade Screw Driver
- Torque Wrench

Fasteners Needed from Parts Bag:

Hoses Needed:

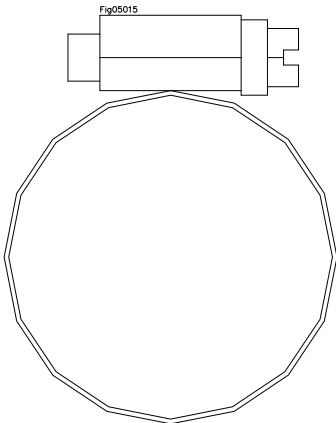

Tank to Pump Hose Clamp
Qty 1
110900 and 1131 Only

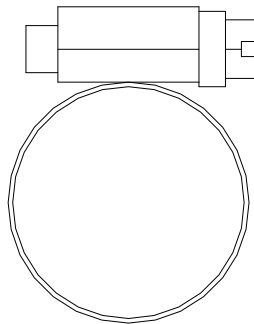

Tank to Pump Hose Clamp
Qty 1
110800 Only



Tank to Hydraulic Pump Hose
Suction Hose, 14" x 3/4" ID
Qty 1, Model 110800 Only



Tank to Hydraulic Pump Hose
Suction Hose, 17.5" x 1" ID
Qty 1, Model 110900, 1131 Only

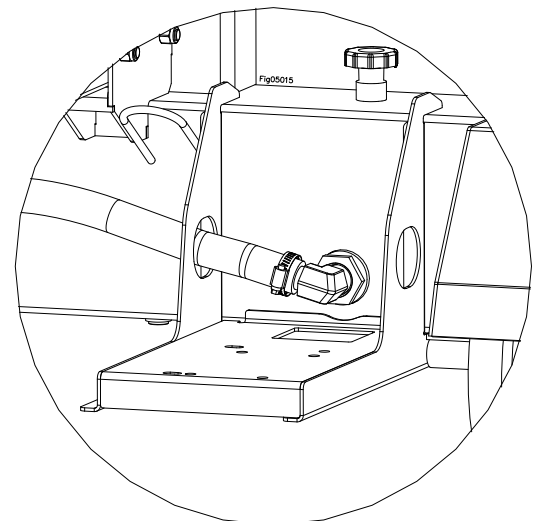
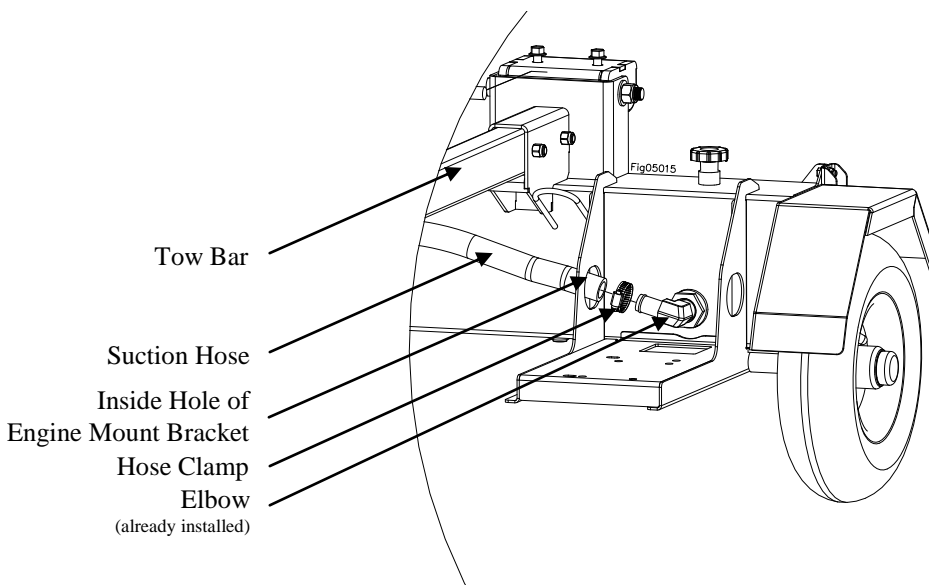

Assembly Instructions

Step 7 – Engine to Tank

Note: Throttle cable is assembled to the engine. Cable routing will be shown in a future step.

- Mount fully assembled engine and pump to engine mount bracket on the hydraulic tank assembly using (4) engine bolts and (4) nuts.
- Torque to 21 ft.-lb.

Tools Needed

- 13mm Wrench
- Torque Wrench

Fasteners Needed from Parts Bag:

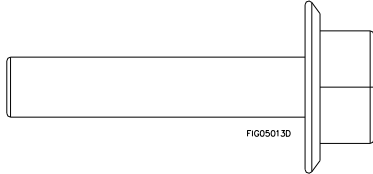

Engine to Tank
Flange Bolt
Qty 4

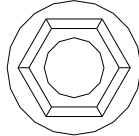

Engine to Tank
Flange Nut
Qty 4

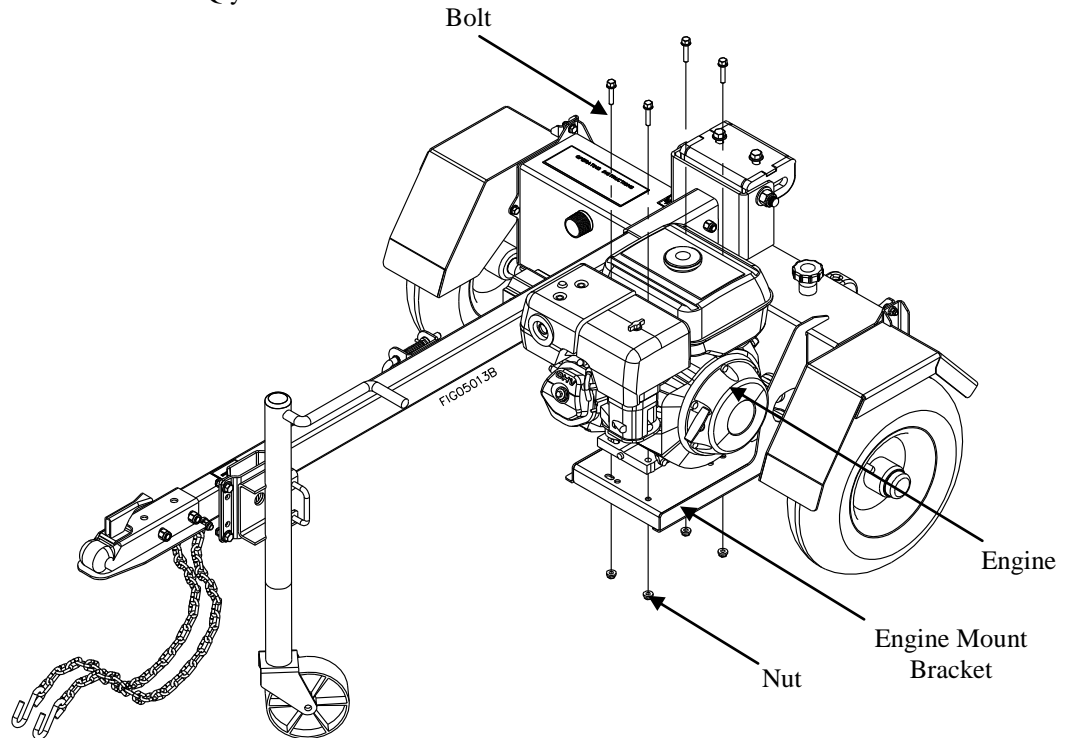

Assembly Instructions

Step 8 – Suction Hose from Tank to Pump

- In step 6, a piece of suction hose was installed to the fitting on the hydraulic tank assembly.
- Locate the other end of the suction hose and the hydraulic pump as show below.
- Loosen hose clamp as necessary. Slide hose clamp onto end of suction hose and push onto pump fitting.
- Secure and tighten hose clamp around the suction hose and pump fitting. Torque to 78 in.-lb.
- Hose clamp must have a tight seal to prevent hydraulic oil from leaking.

Tools Needed

- Flat Blade Screw Driver
- Torque Wrench

Fasteners Needed from Parts Bag:

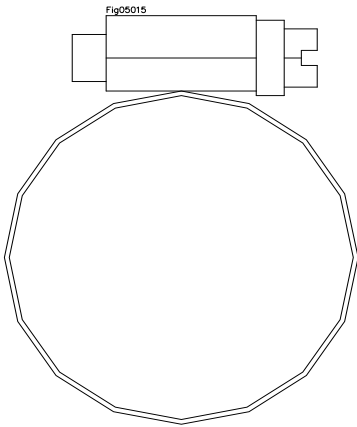

Tank to Pump Hose Clamp
Qty 1
110900 and 1131 Only

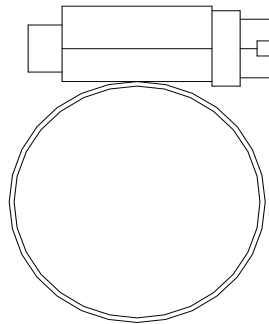

Tank to Pump Hose Clamp
Qty 1
110800 Only

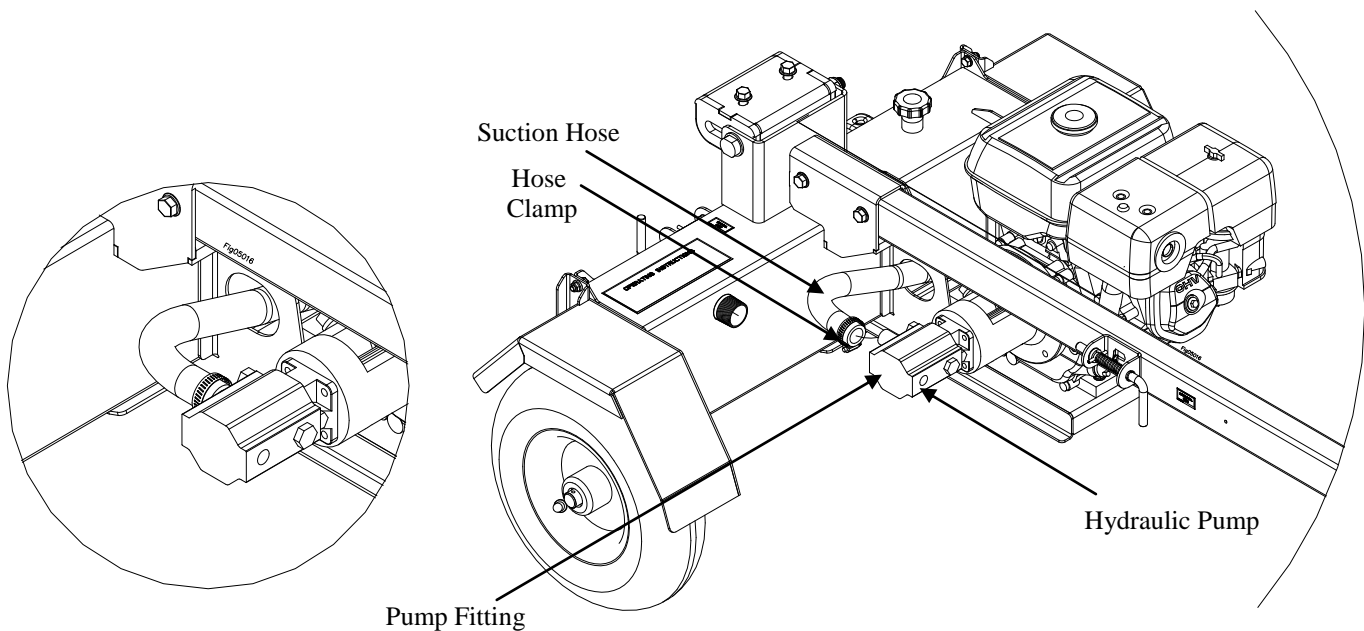

Assembly Instructions

Step 9 – Outrigger Leg to Tank

- Connect the rear outrigger leg to the backside of the hydraulic tank assembly
- Tighten nut until snug then back off 1/2 turn
- NOTE: Once the Outrigger Leg is installed, lock the leg in the down position.

Tools Needed

- 15mm Wrench
- 16mm Wrench

Fasteners Needed from Parts Bag:

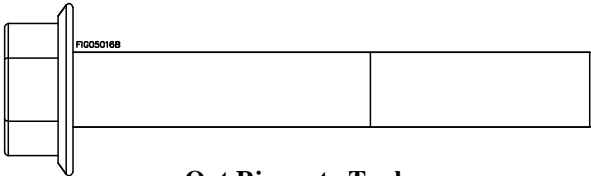

Out Rigger to Tank
Flange Bolt
Qty 1

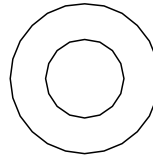

Out Rigger to Tank
Washer
Qty 1

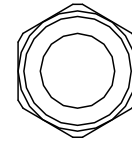

Out Rigger to Tank
Nyloc Nut
Qty 1

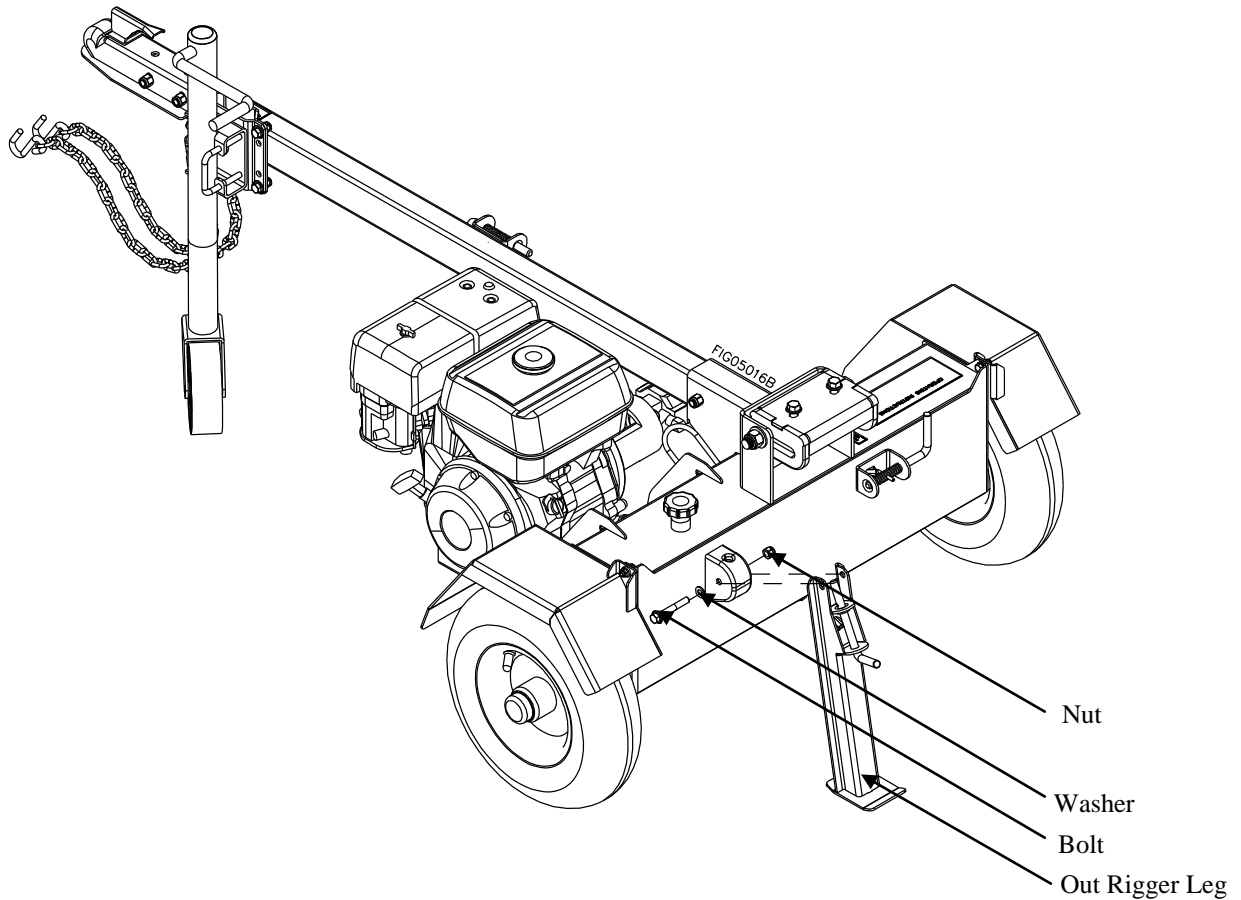

Assembly Instructions

Step 10 – Install Filter and Manual Tube

- Screw finger-tight (1) Return Line Filter Head onto hydraulic tank return port. *NOTE: The arrow on filter head should point towards the tank.*
- Wrench-tighten the fitting to 1.5-3.0 Turns Past Finger Tight position. Consider final orientation position as to not exceed the recommended Turns Past Finger Tight. Properly assembled fittings total thread engagement should be 3.5-6 turns.
- **CAUTION:** Never back off an installed pipe fitting to achieve proper alignment. Loosening installed pipe fittings will corrupt the seal and contribute to leakage and failure.
- Screw finger-tight (1) Return Line Filter Canister onto bottom of return line filter head until gasket makes contact/hand tight. Then, tighten filter an additional 1/4 turn.
- Remove the manual tube cover from manual tube
- Align holes in manual tube with holes in tow bar
- Secure the manual tube to tow bar using (3) Self-Tapping Screws
- Reattach the manual tube cover onto the manual tube.

Tools Needed

- Pipe Wrench
OR
- Crescent Wrench
- 11mm Wrench

Fasteners Needed from Parts Bag:

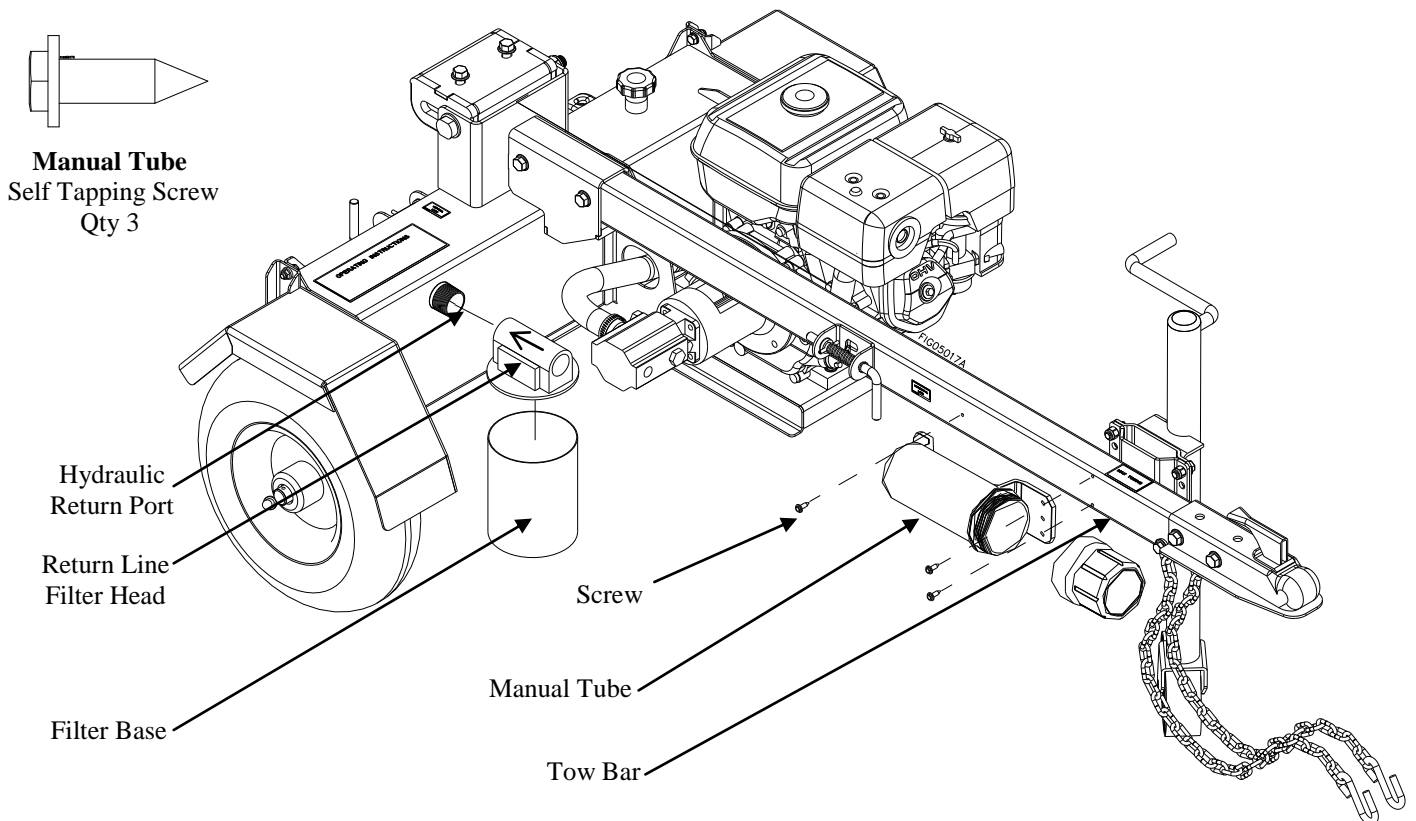

Assembly Instructions

Step 11 – Install Beam Assembly

NOTE: *Nut and bolt are installed (hand tight only) on pivot bracket for packaging purposes.*

- **Step 11 A:** Remove nut and bolt. They will be re-installed.
- **Step 11 B:** Push pivot bracket so that it is parallel to the back side of tank.
- **Step 11 C:** Stand beam assembly on end plate with the help of another person. Have that person hold the beam in place while maneuvering the log splitter as shown in Step 11 D.

Tools Needed

- 18mm Wrench (2 Needed)
- Torque Wrench

Fasteners Needed from Parts Bag:

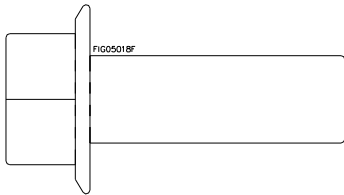

Beam to Pivot Bracket
Flange Bolt
Qty 2

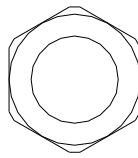

Beam to Pivot Bracket
Nyloc Nut
Qty 2

Step 11 A

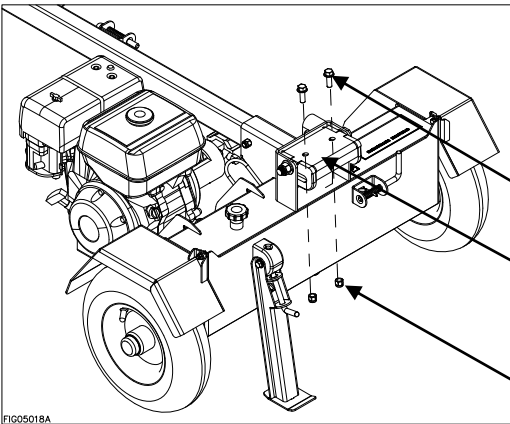

- Bolt
- Pivot Mount Bracket
- Nut

Step 11 B

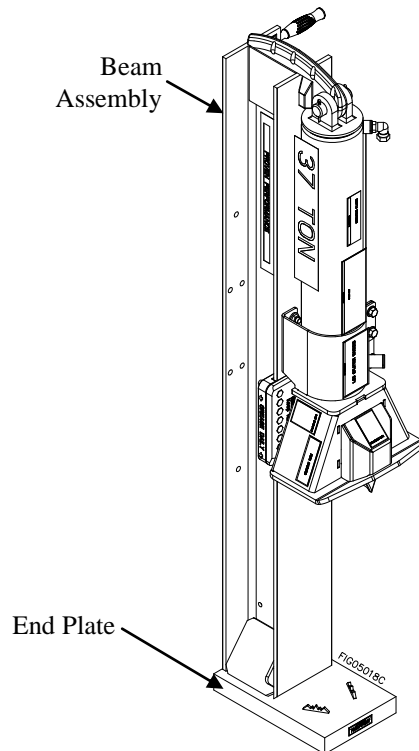
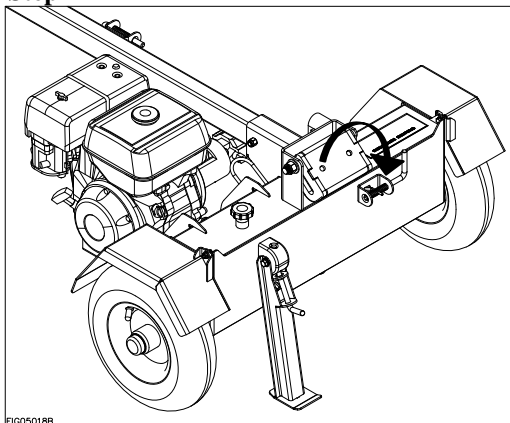

Assembly Instructions

Step 11 – Install Beam Assembly Cont'd

- **Step 11 D:** Maneuver log splitter and align with the beam as shown below.
- **NOTE:** Once log splitter is in line with beam, put the out rigger leg in the **DOWN** position to stabilize splitter for assembling.
- Insert (2) bolts and thread (2) nuts onto bolts.
- Torque to 71 ft.-lb.

Tools Needed

- 18mm Wrench (2 Needed)
- Torque Wrench

Step 11 D

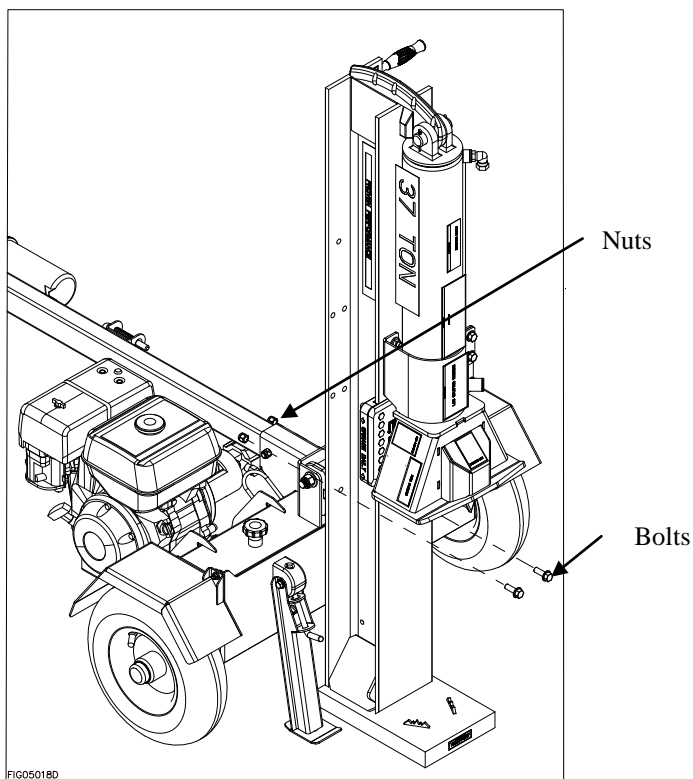

Complete View

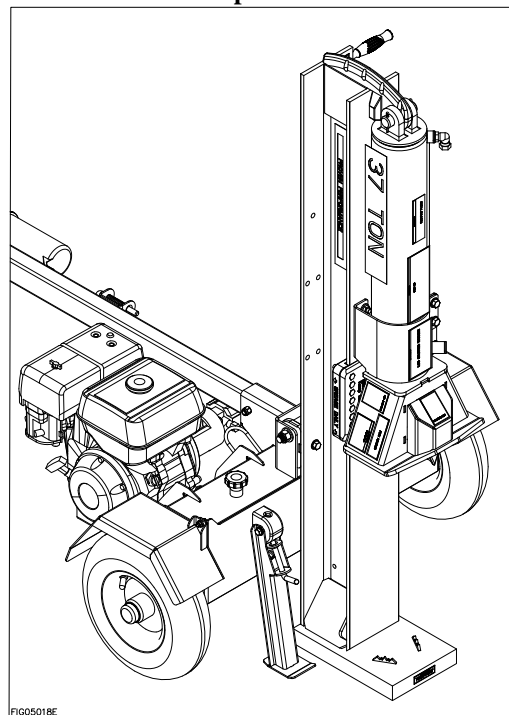

Assembly Instructions

Step 12 – Horizontal Latch to Beam

- Align horizontal latch to beam using (2) bolts and (2) nuts.
- Torque to 71 ft.-lb.
- Ensure that the Outrigger leg is in the DOWN position.
- Using the handle on the beam, lower beam to the tow bar. Pull horizontal lock latch rod outwards to allow the beam to rest properly on the tow bar. Push latch rod forward to lock in the horizontal position.
- See page 20 for further instruction.
- Note: If horizontal latch bracket does not latch correctly. Loosen bolts/nuts and adjust horizontal latch bracket. If further adjustment is needed, loosen bolts/nuts from Step 11 and adjust pivot mount bracket.

Tools Needed

- 18mm Wrench
(2 Needed)
- Torque Wrench

Fasteners Needed from Parts Bag:

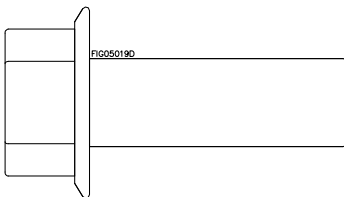

Horizontal Latch to Beam
Flange Bolt
Qty 2

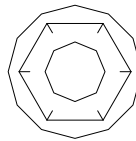

Horizontal Latch to Beam
Flange Nut
Qty 2

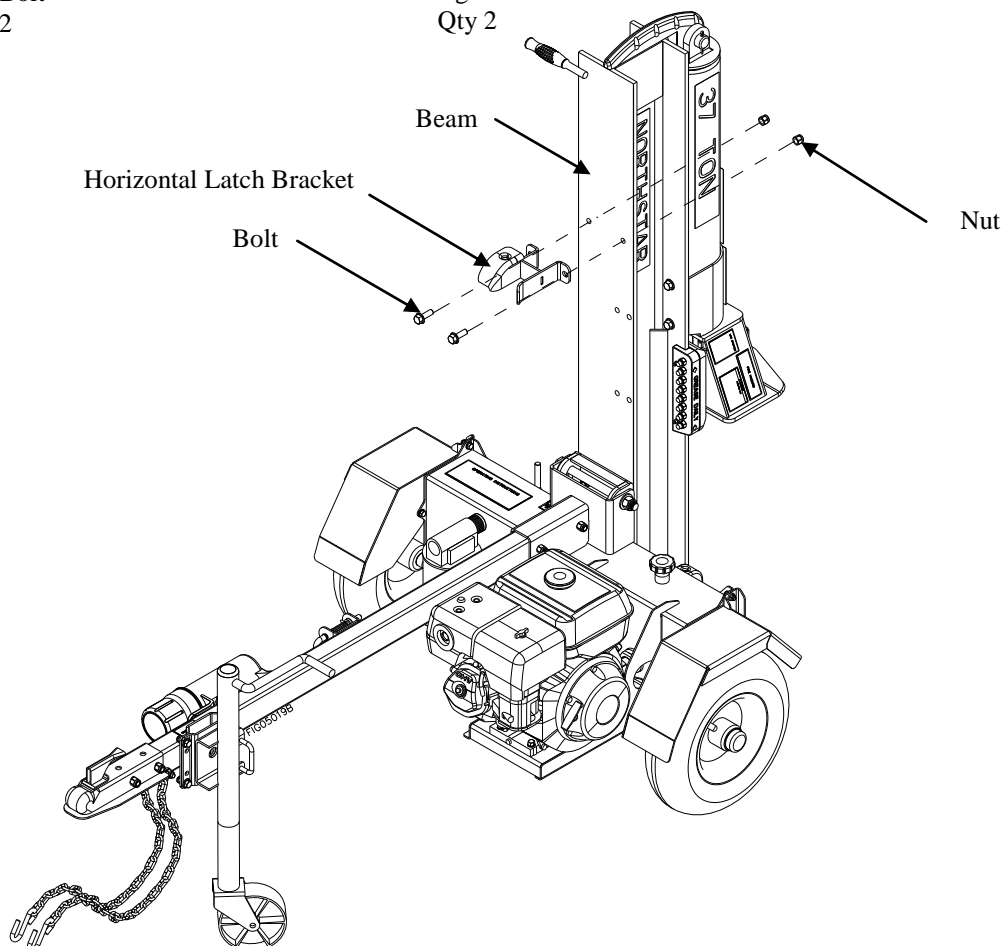

Assembly Instructions

Step 13 – Log Tables to Beam

- Align right side log table to beam and insert the top (2) bolts and bottom (2) bolts.
- Align left side log table to the bolts inserted above. Add (4) nuts onto bolts and secure tightly.
- Torque to 21 ft.-lb.
- Note: It may be helpful to have another person assist with this step.

Tools Needed

- 13mm Wrench
- Torque Wrench

Fasteners Needed from Parts Bag:

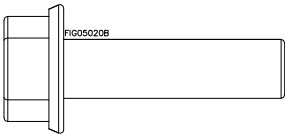

Log Cradle to Beam
Flange Bolt
Qty 4

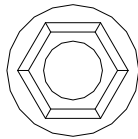

Log Cradle to Beam
Flange Nut
Qty 4

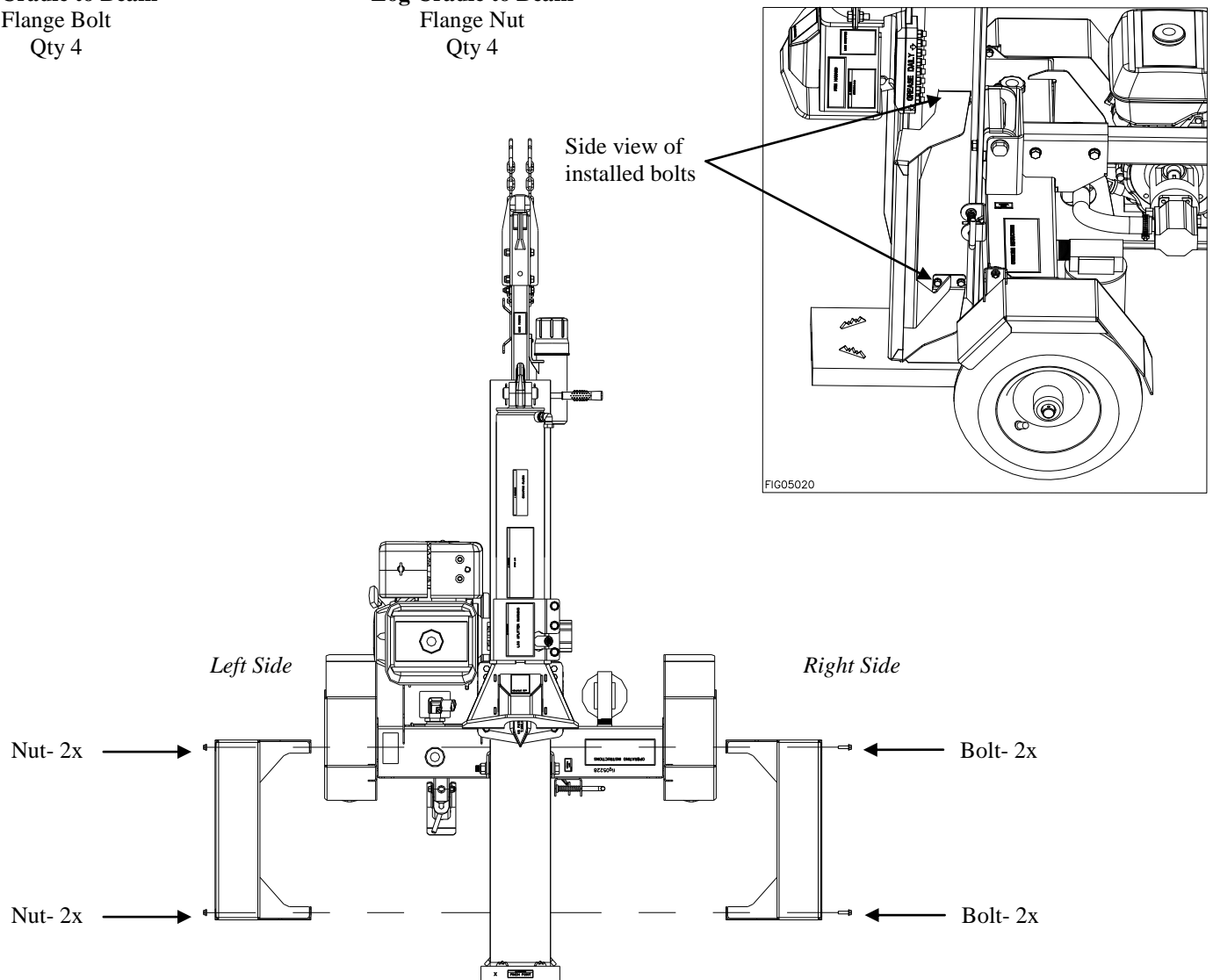

Assembly Instructions

Step 14 – Throttle Cable Setup

Step 14 only applies to Models 110900 and 1131

- One end of the throttle cable is connected to the engine. Route unattached end of cable from engine downward towards engine mount bracket. Ensure cable routes thru the hose guide.
- There is (1) crimped clamp secured on the cable and (1) vinyl coated clamp that is free moving on the cable.
- Insert bolt thru the crimped clamp that attaches the cable to the engine mount bracket. Secure with nut. Torque to 21 ft.-lb.
- Vinyl coated loop clamp will be connected to engine guard bolt in a future step.

Tools Needed

- 13mm Wrench (2 Needed)
- Torque Wrench

Fasteners Needed from Parts Bag:

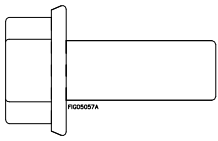

**Engine Throttle Clamp
to Engine Mount**
Flange Bolt
Qty 1

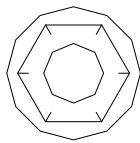

**Engine Throttle Clamp to
Engine Mount**
Flange Nut
Qty 1

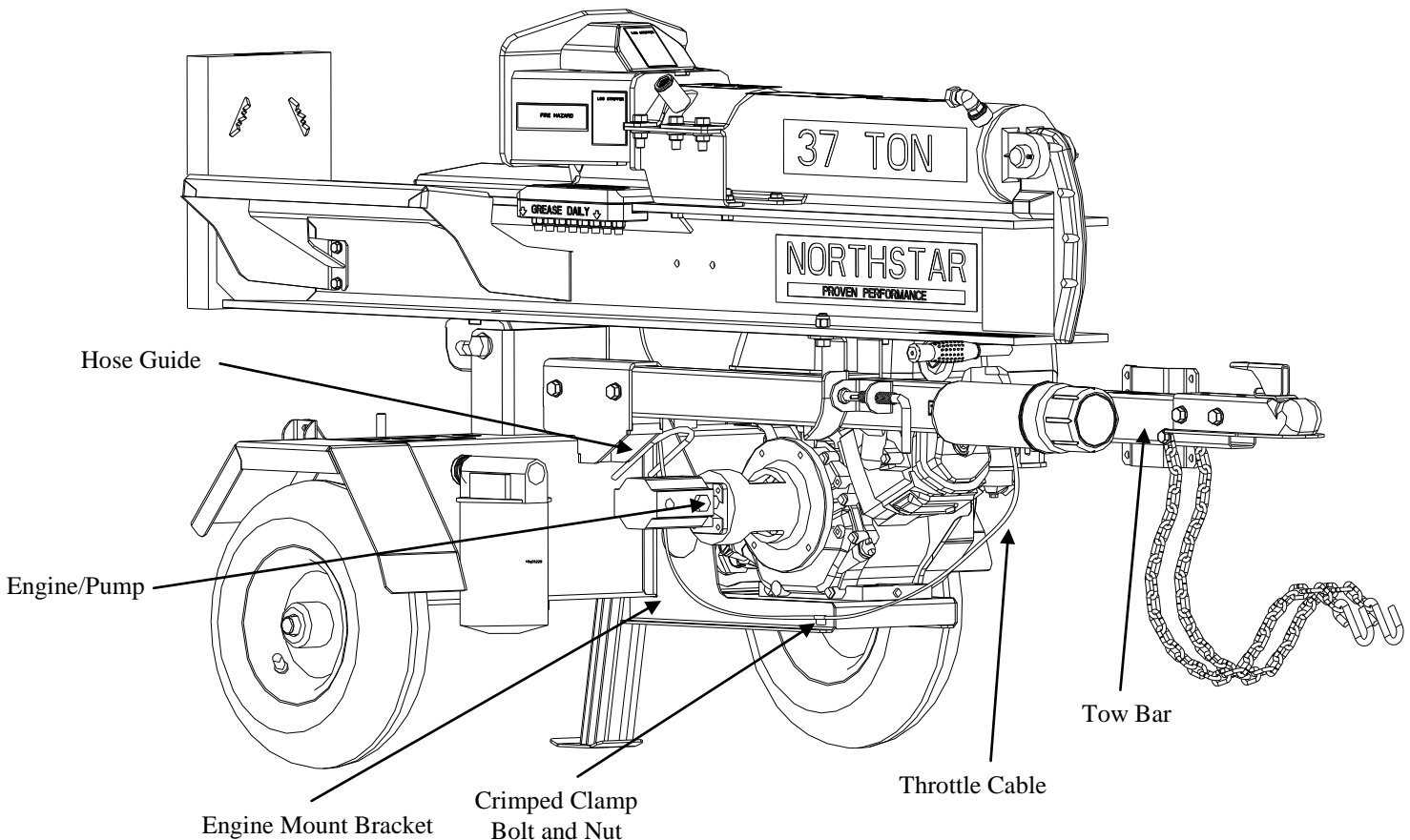

Assembly Instructions

Step 14 – Throttle Cable Setup Cont.

- Lower beam to horizontal position and lock the horizontal latch as shown
- Attach free end of throttle cable to bracket as shown below. Tighten nuts on cable to secure throttle cable to bracket.
- Attach throttle bracket assembly to beam using (2) Throttle Cable to Beam Flange Bolts and (2) Throttle Cable to Beam Flange Nut.
- Align bolts in center of slots on throttle bracket. Torque to 21 ft.-lb.
NOTE: Adjust throttle bracket forward or backward for optimal engine performance.

Tools Needed

- 13mm Wrench
2 Needed
- Torque Wrench

Fasteners Needed from Parts Bag:

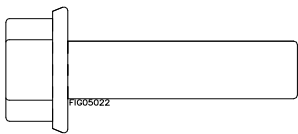

**Throttle Cable to Beam
Flange Bolt**
Qty 2

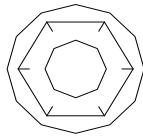

**Throttle Cable to Beam
Flange Nut**
Qty 2

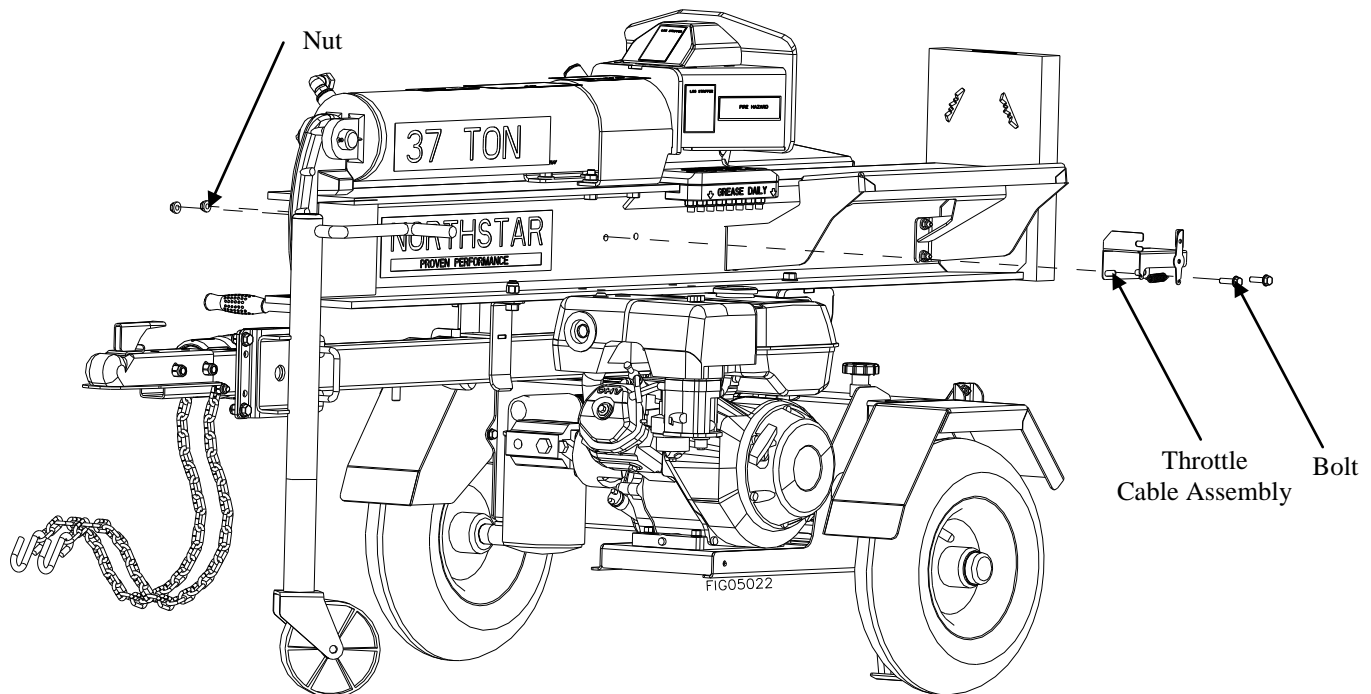
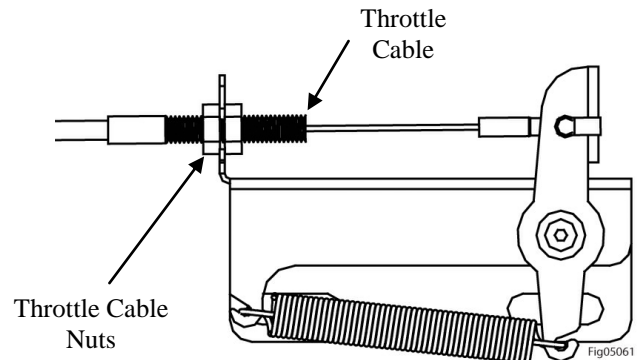

Assembly Instructions

Step 15 – Engine Guard to Beam

NOTE: Engine guard installation varies for all models due to engine size Assemble to engine guard to the beam in the horizontal position

- Align engine guard bracket to the two sets of holes in the beam
- Slide the vinyl coated clamp located on throttle cable to the hole on the engine guard shown below. See next page for correct clamp location.
- 110800 Only: Using (4) bolts, (4) nuts and (4) washers, secure engine guard to beam.
- 110900 & 1131 Only: Using (4) bolts, (4) nuts, and (3) washers, secure engine guard to beam. Secure vinyl coated loop clamp from previous step to underside of beam as shown. Do not use washer on bolt used to secure loop clamp.
- Torque to 20 ft.lb. CAUTION: Over-tightening can crush tube.

Tools Needed

- 13mm Wrench (2 Needed)
- Torque Wrench

Fasteners Needed from Parts Bag:

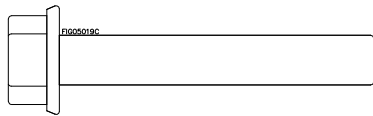

Engine Guard to Beam
Flange Bolt
Qty 4



Engine Guard to Beam
Nyloc Nut
Qty 4

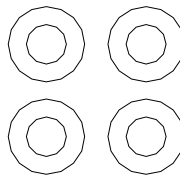

Engine Guard to Beam
Flat Washer
110800 Qty 4, 110900 & 1131 Qty 3

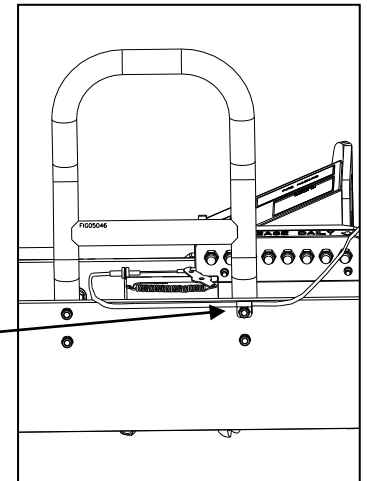

Secure vinyl coated loop clamp to this bolt.

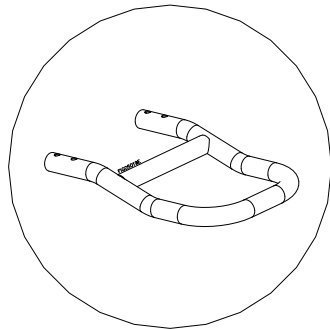

Note: Models 110800 & 110900
Engine guard curves downwards

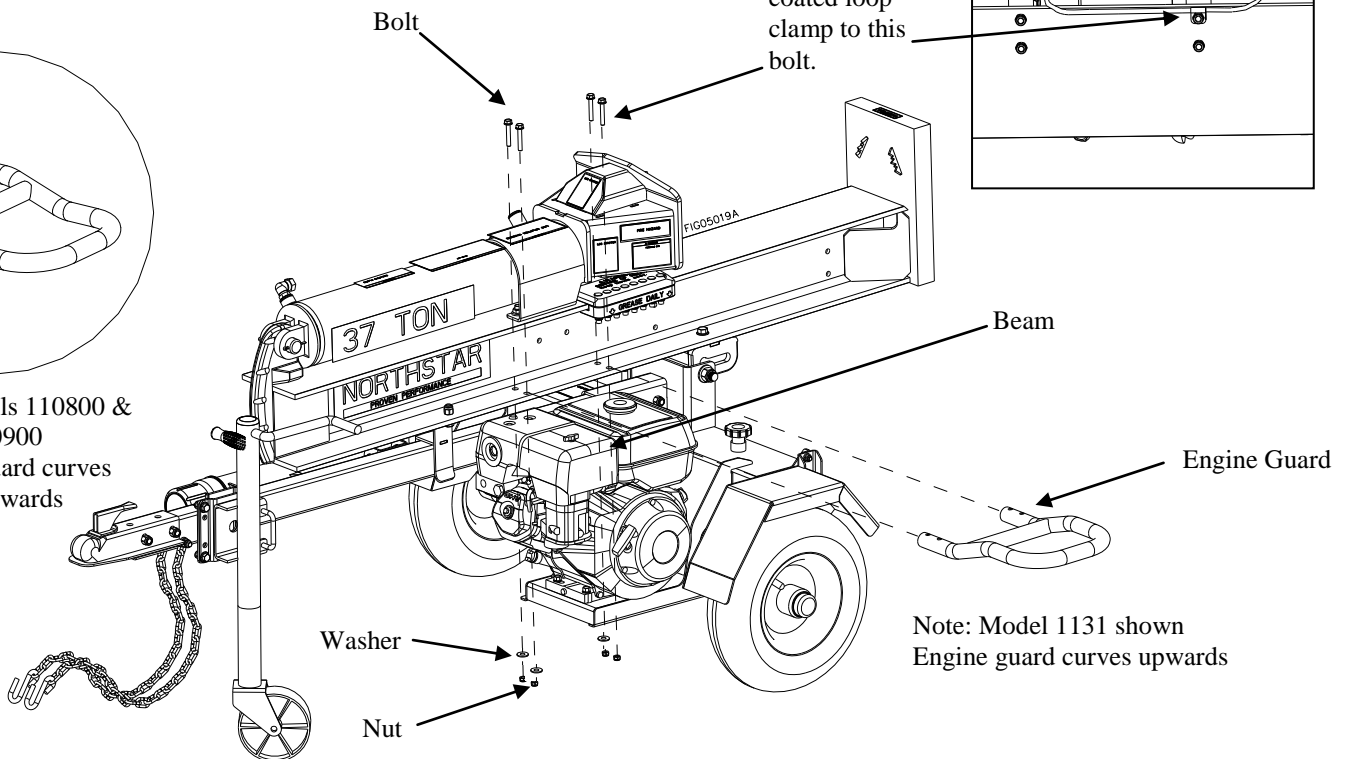

Note: Model 1131 shown
Engine guard curves upwards

Assembly Instructions

Step 15 – Engine Guard to Beam Cont.

- Position vinyl coated loop clamp so that throttle cable routing is similar to what is depicted below. NOTE: Distance from throttle bracket assembly to end of throttle cable should be at least 2.5”.

Tools Needed

- 13mm Wrench (2 Needed)
- Torque Wrench

Length = 2.5”

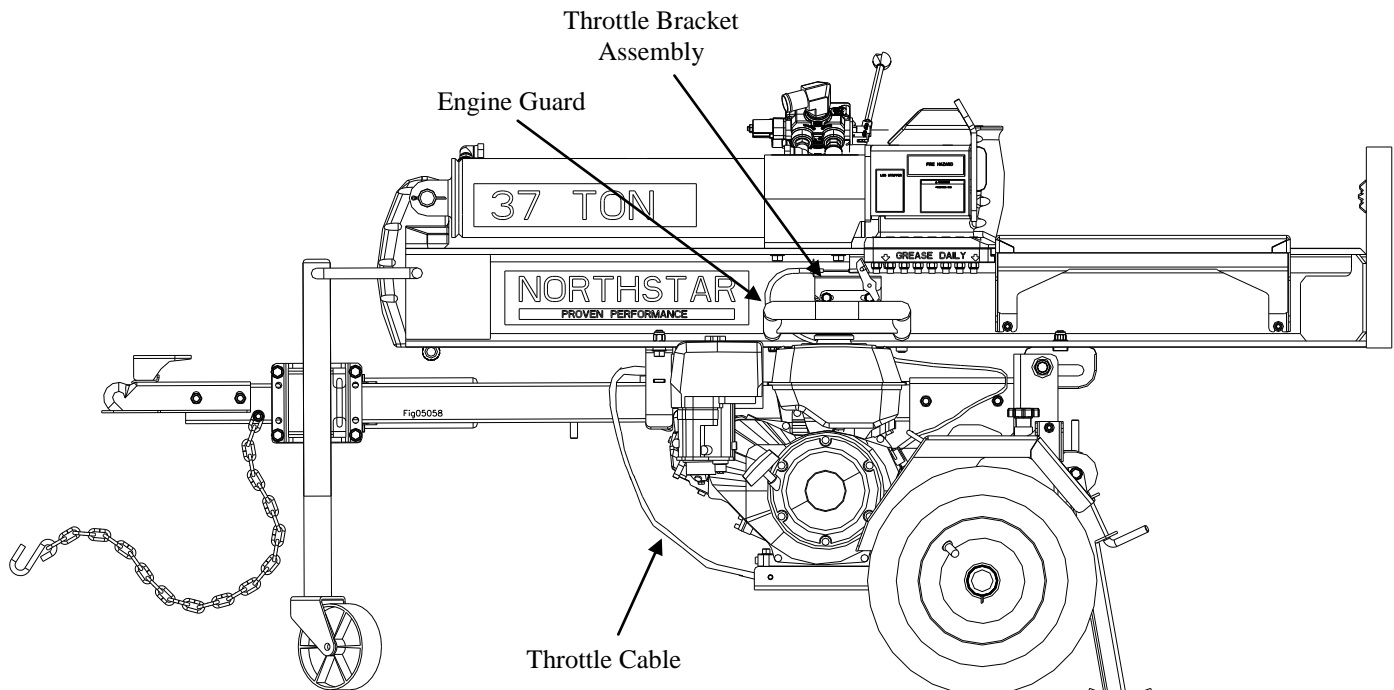
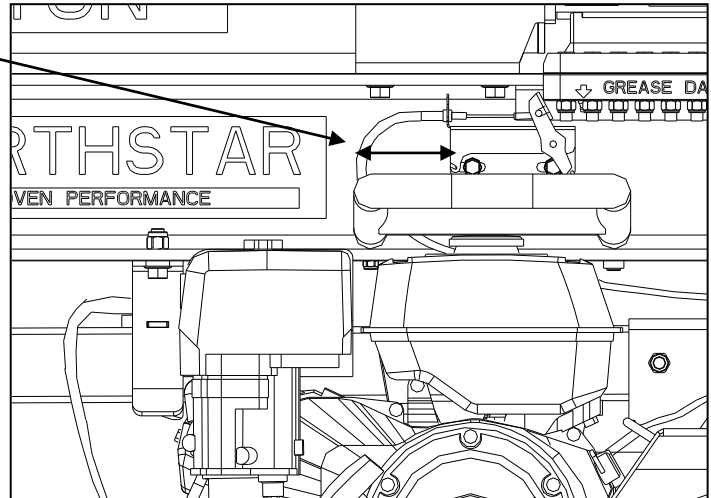

Assembly Instructions

Step 16 – Control Valve

- Slide control valve handle into the clevis slots on the control valve.
- Align holes in handle with clevis holes.
- Insert the supplied pins through holes and secure with supplied bridge clips.

Tools Needed

- Pliers

Parts Needed from Valve Box:

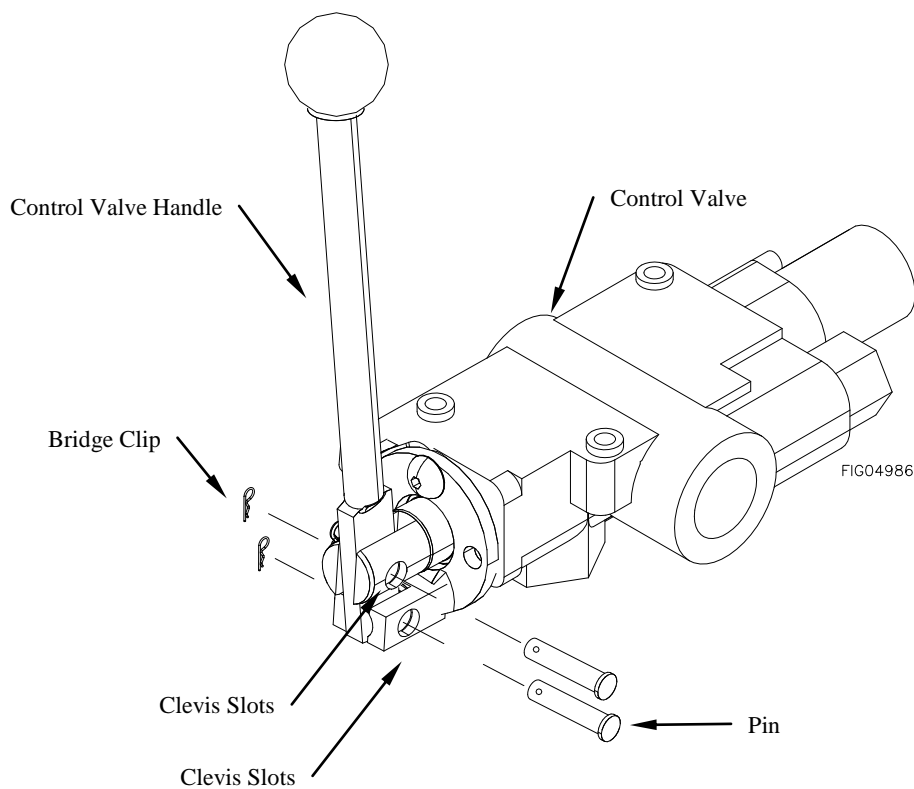
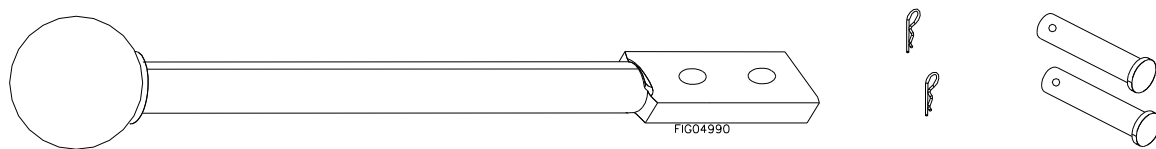

Assembly Instructions

Step 17 – Valve Installation

- Remove plug from cylinder port and discard
- Lubricate O-ring and threads on fitting with clean oil
- Orientate (1) Valve Fitting so that nut/washer/O-ring assembly is facing up. Turn fitting into cylinder port until finger-tight
- Torque to 27-43 ft.-lb.
- Looking at fitting from end with nut/washer/O-ring assembly, turn nut clockwise as far as possible
- Use valve port marked “A” to thread the control valve onto the fitting until control valve touches washer
- Hold control valve in orientation shown below and torque nut to 37-46 ft.-lb.

Tools Needed

- 7/8” Wrench
(2 needed)
OR
- Crescent Wrench
(2 needed)
- Torque Wrench

Fitting Needed from Parts Bag:

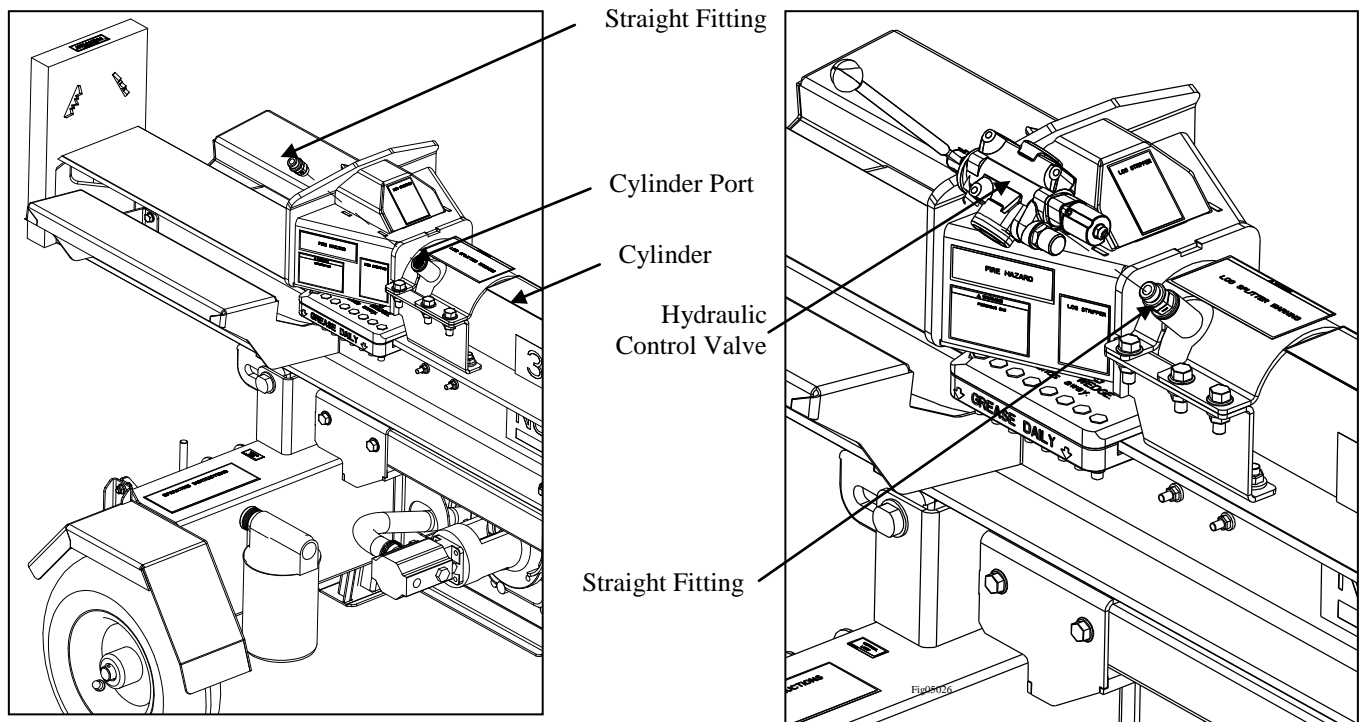
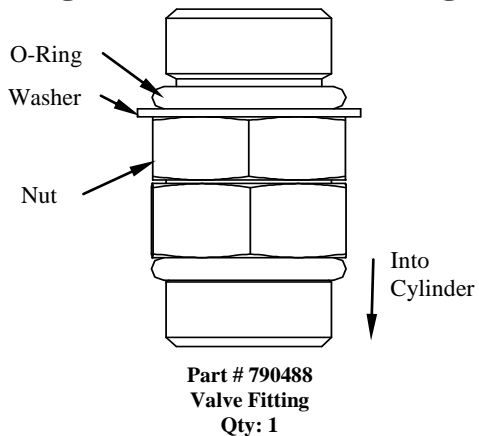

Assembly Instructions

Step 17 – Valve Installation Continued

- Remove plugs from ports in control valve
- Lubricate O-ring and threads on fitting with clean oil
- Looking at fitting from end with nut/washer/O-ring assembly, turn nut clockwise as far as possible
- Using wrench, turn (1) Valve to Hydraulic Pump Fitting into valve port marked “IN” until washer touches control valve. Continue turning until washer touches thread nearest wrench pad
- Back off fitting counterclockwise not exceeding one revolution until it is oriented in the correct position
- Place wrench on the wrench pad of fitting to prevent fitting from turning and torque nut to 70-87 ft.-lb.

Tools Needed

- 7/8” Wrench
- 1” Wrench
- OR
- Crescent Wrench (2 needed)
- Torque Wrench

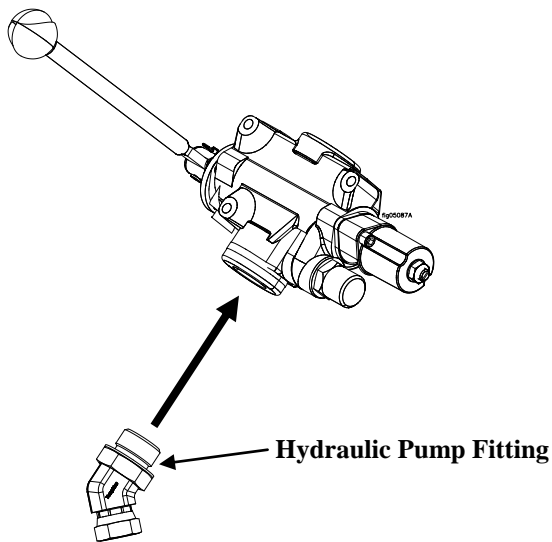

Fitting Orientation

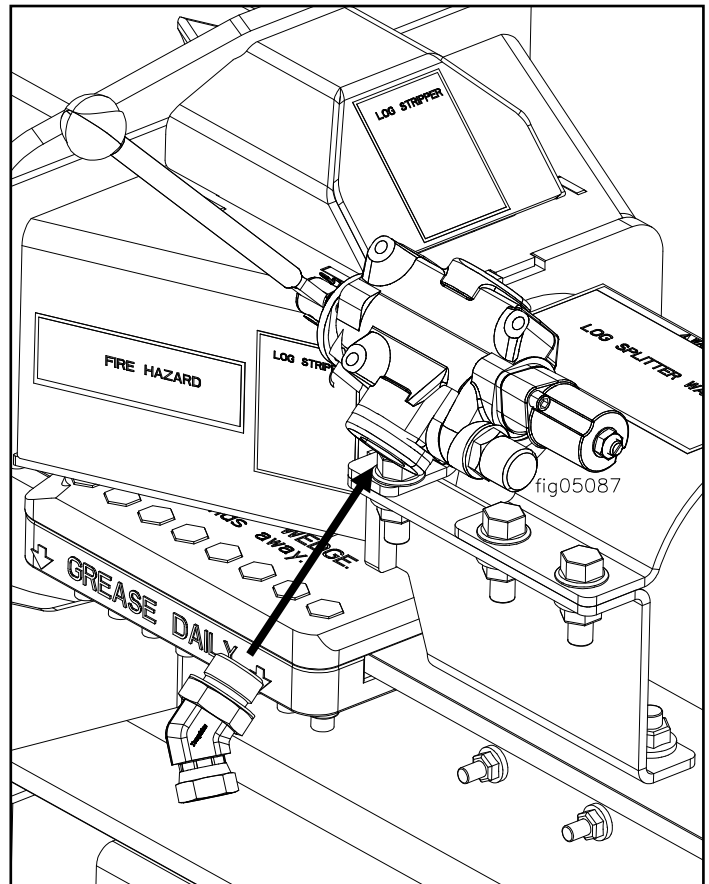
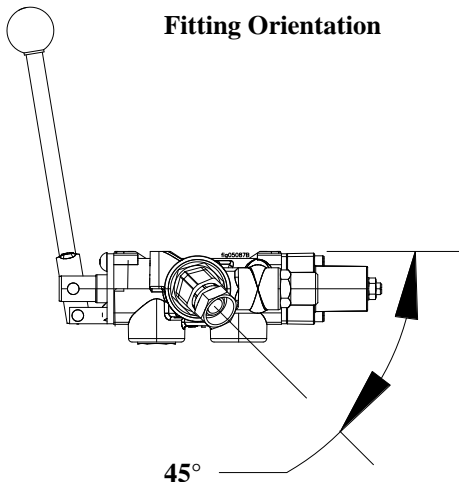

Assembly Instructions

Step 17 – Valve Installation Continued

- Remove plugs from ports in control valve
- Lubricate O-ring and threads on fitting with clean oil
- Looking at fitting from end with nut/washer/O-ring assembly, turn nut clockwise as far as possible
- Using wrench, turn (1) Valve to Cylinder Fitting into valve port marked “B” until washer touches control valve. Continue turning until washer touches thread nearest wrench pad
- Back off fitting counterclockwise not exceeding one revolution until it is oriented in the correct position
- Place wrench on the wrench pad of fitting to prevent fitting from turning and torque nut to 37-46 ft.-lb.

Tools Needed

- 1” Wrench
- 1 1/4” Wrench
OR
- Crescent Wrench
(2 needed)
- Torque Wrench

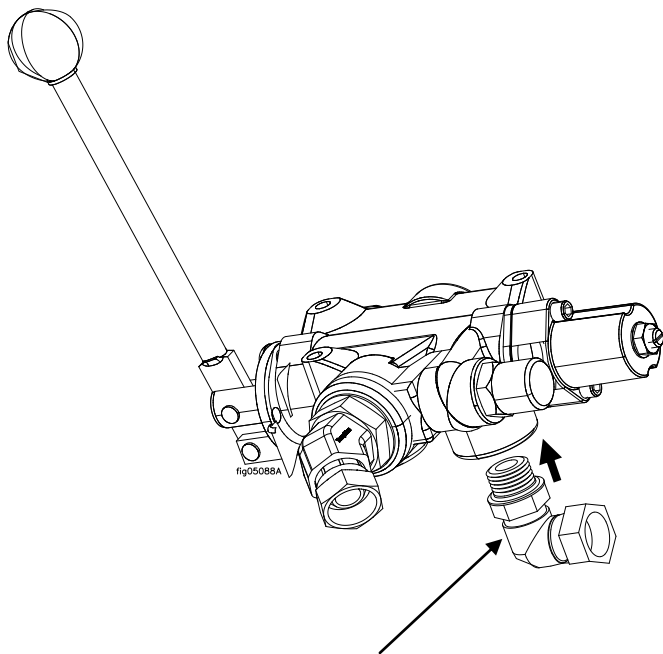

Valve to Cylinder Fitting

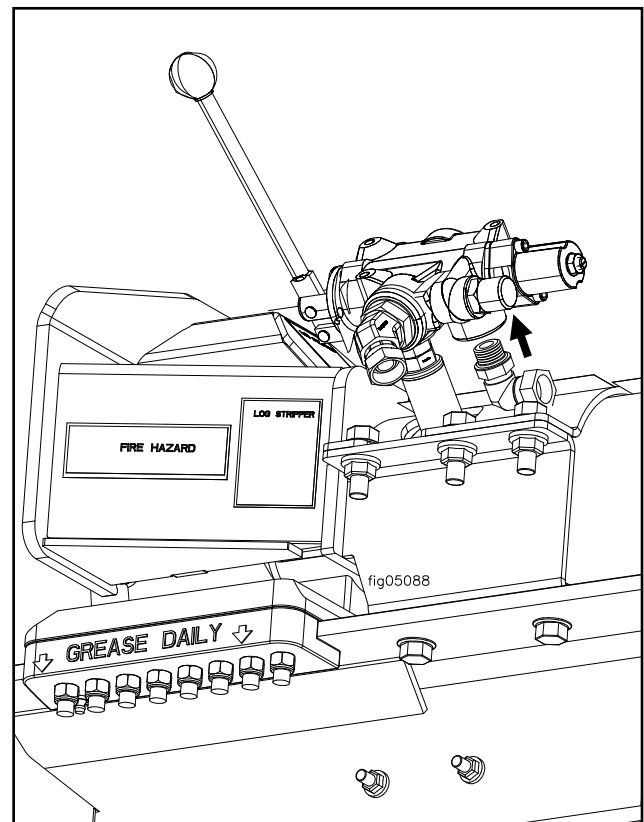

Assembly Instructions

Step 17 – Valve Installation Continued

- Remove plugs from ports in control valve
- Lubricate O-ring and threads on fitting with clean oil
- Looking at fitting from end with nut/washer/O-ring assembly, turn nut clockwise as far as possible
- Using wrench, turn (1) Valve to Hydraulic Filter Fitting into valve port marked “OUT” until washer touches control valve. Continue turning until washer touches thread nearest wrench pad
- Back off fitting counterclockwise not exceeding one revolution until it is oriented in the correct position
- Place wrench on the wrench pad of fitting to prevent fitting from turning and torque nut to 70-87 ft.-lb.

Tools Needed

- 1 5/16” Wrench
- 1 5/8” Wrench
OR
- Crescent Wrench
(2 needed)
- Torque Wrench

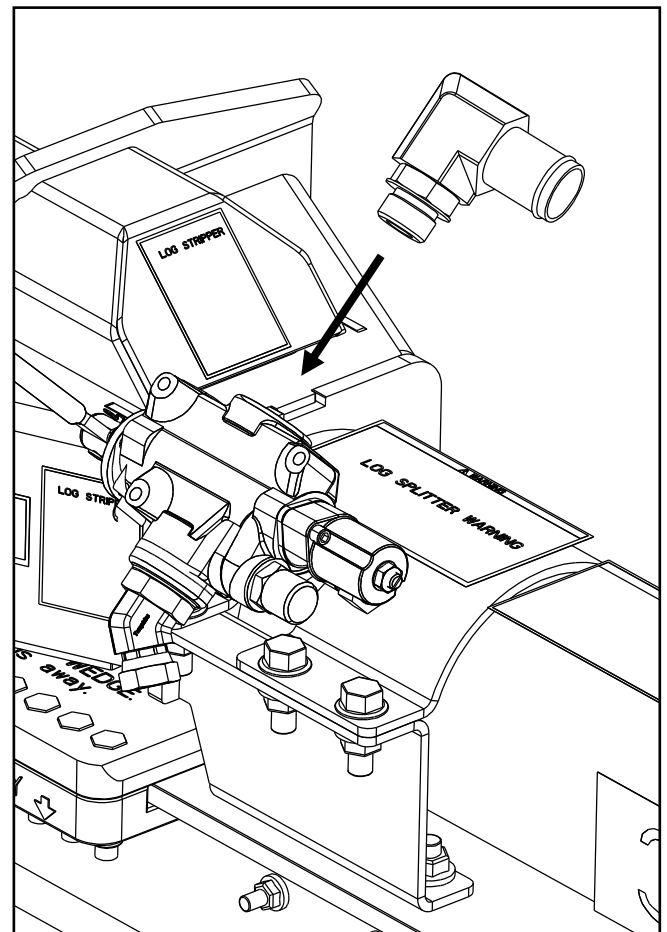
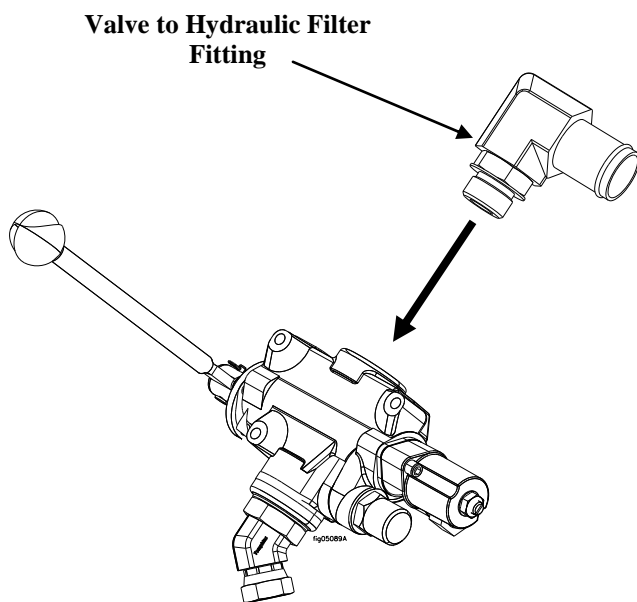

Assembly Instructions

Step 17 – Valve Installation Continued

- Align valve plate to the top three holes on the mounted valve.
- Using (3) Screws and (3) Nuts secure plate to valve.
- Torque to 102 in.-lb.

Tools Needed

- 10mm Wrench
- Philips Screw Driver
- Torque Wrench

Fasteners Needed from Parts Bag:

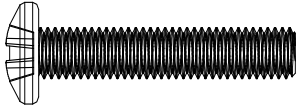

**Valve Plate
Cap Screw**
Qty 3



**Valve Plate
Nyloc Nut**
Qty 3

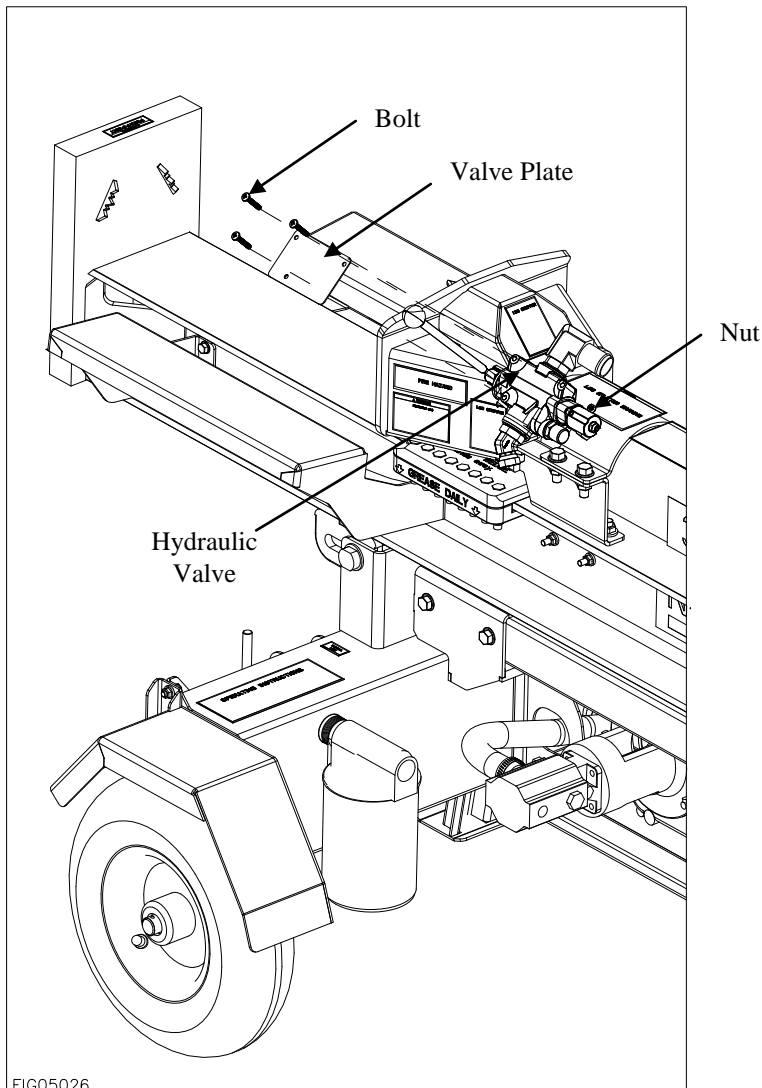

FIG05026

Assembly Instructions

Step 18 – High Pressure Hose Routing

- Route (1) Short High Pressure Hose from the Valve to Cylinder Fitting on the control valve to the 90° Elbow Cylinder
- Screw finger-tight Short High Pressure Hose to the Valve to Cylinder Fitting
- Wrench tighten 1.5-3.0 Turns Past Finger Tight
- Screw finger-tight remaining end of Short High Pressure Hose to the 90° Elbow Cylinder
- Wrench tighten 1.5-3.0 Turns Past Finger Tight

Tools Needed

- 1" Wrench
- 7/8" Wrench
OR
- Crescent Wrench
(2 Needed)

Hoses Needed:

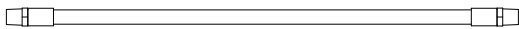

Valve to Cylinder Hose

High Pressure Hose, 21.75" x 1/2" ID with
1/2" Male NPT fittings
Qty 1

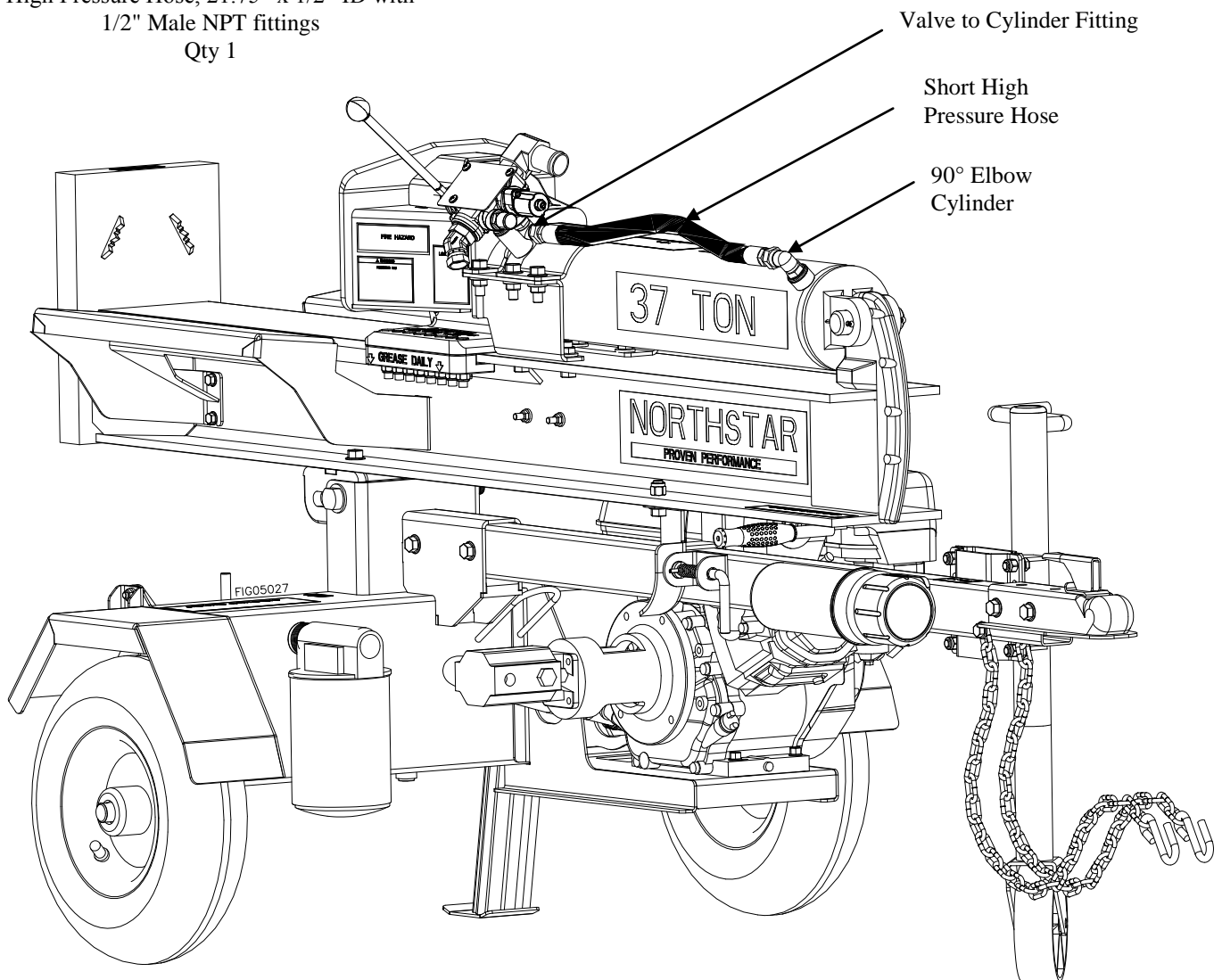

Assembly Instructions

Step 18 – High Pressure Hose Routing Cont'd

- Remove plug from pump.
- Screw finger-tight (1) Hydraulic Pump Fitting into the pump
- Wrench-tighten the fitting to 1.5-3.0 Turns Past Finger Tight position. Consider final orientation position as to not exceed the recommended TPFT. Properly assembled fittings total thread engagement should be 3.5-6 turns.
- CAUTION: Never back off an installed pipe fitting to achieve proper alignment. Loosening installed pipe fittings will corrupt the seal and contribute to leakage and failure.
- Route (1) Long High Pressure Hose from the Valve to Hydraulic Pump Fitting on the control valve to the Hydraulic Pump Fitting
- Screw finger-tight Long High Pressure Hose to Valve to Hydraulic Pump Fitting
- Wrench tighten 1.5-3.0 Turns Past Finger Tight
- Screw finger-tight remaining end of Long High Pressure Hose to the Hydraulic Pump Fitting
- Wrench tighten 1.5-3.0 Turns Past Finger Tight

Tools Needed

- 1" Wrench
- 7/8" Wrench
- OR
- Crescent Wrench (2 Needed)

Hose Needed:

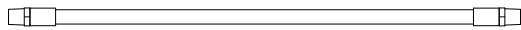

Valve to Hydraulic Pump
High Pressure Hose, 56" x 1/2" ID with
1/2" Male NPT fittings
Qty 1

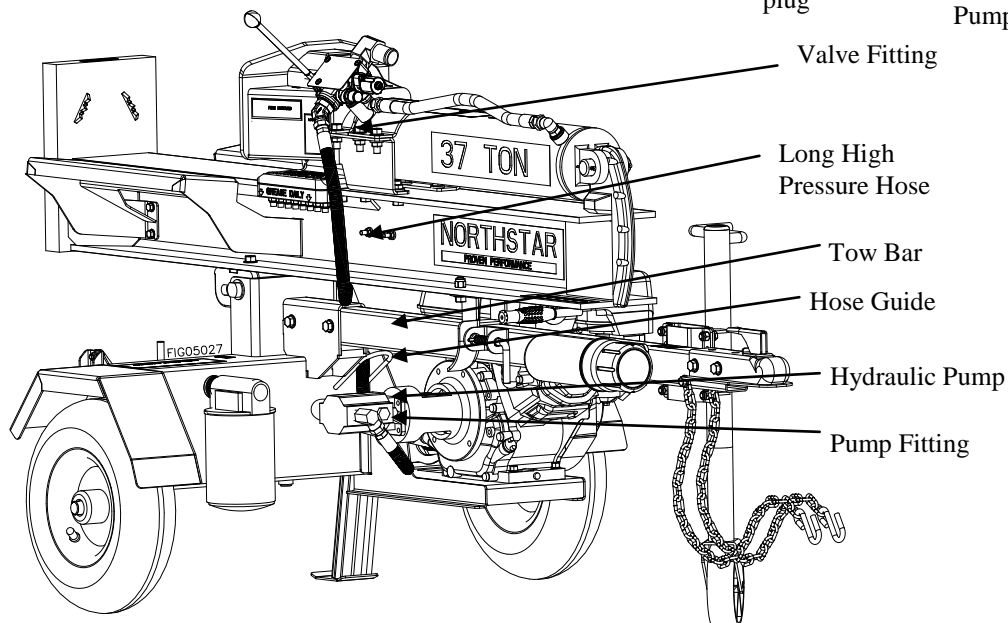
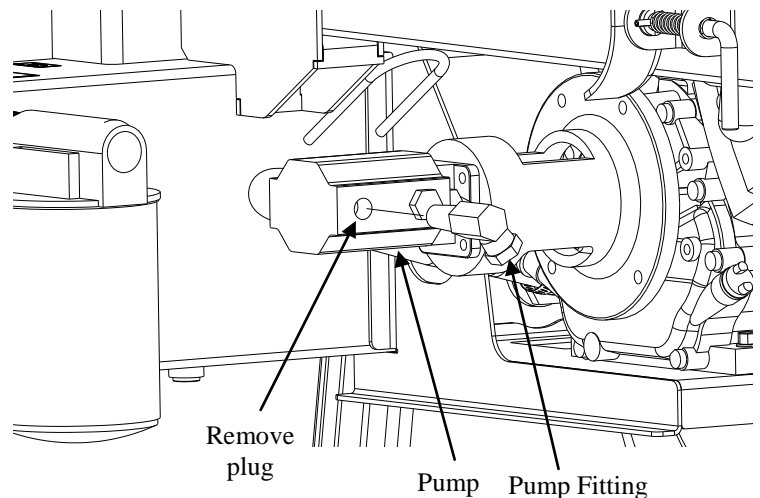

Assembly Instructions

Step 19 – Suction Hose Routing

- Screw finger-tight (1) Filter Fitting into the return line filter head
- Wrench-tighten the fitting to 1.5-3.0 Turns Past Finger Tight position. Consider final orientation position as to not exceed the recommended TPFT. Properly assembled fittings total thread engagement should be 3.5-6 turns.
- **CAUTION:** Never back off an installed pipe fitting to achieve proper alignment. Loosening installed pipe fittings will corrupt the seal and contribute to leakage and failure.
- Add hose clamp and connect one end of the suction hose to the Valve to Hydraulic Tank Fitting. Torque to 77 in.-lb.
- Route hose as shown below
- Add hose clamp and connect remaining end of suction hose to Return Line Filter Fitting. Torque to 77 in.-lb.

Tools Needed

- Flat Blade Screw Driver
- Pipe Wrench
- Torque Wrench

Fittings Needed from Parts Bag:

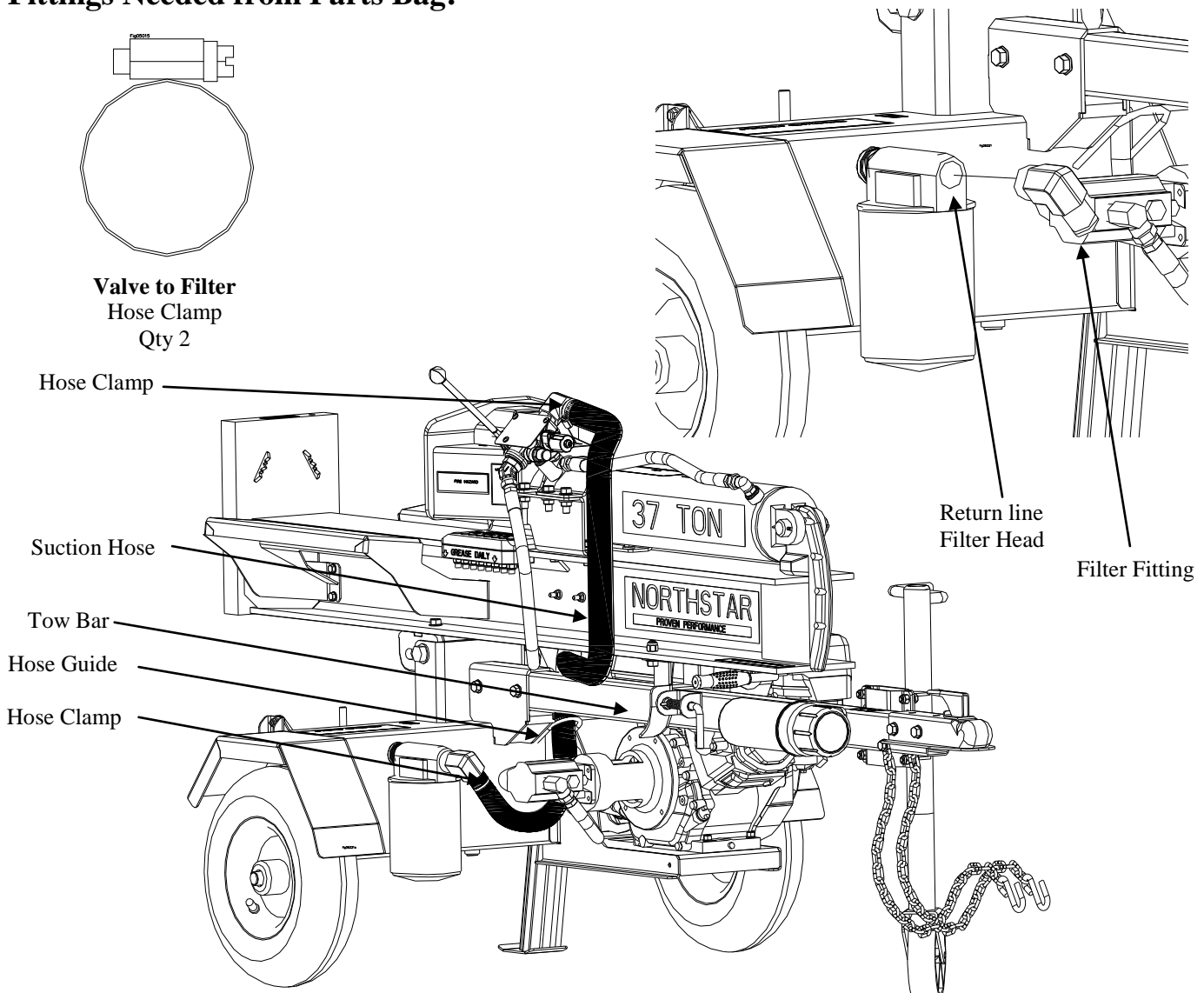

Limited Warranty

Dear Valued Customer:

The NorthStar Product you just purchased is built with the finest material and craftsmanship. Use this product properly and enjoy the benefits from its high performance. By purchasing a NorthStar product, you show a desire for quality and durability. Like all mechanical equipment this unit requires a due amount of care. Treat this unit like the high quality piece of machinery it is. Neglect and improper handling may impair its performance. Please thoroughly read the instructions and understand the operation before using your product. Always contact NorthStar Product Support at 1-800-270-0810 prior to having any service or warranty work performed, as some services performed by parties other than NorthStar approved service centers may void this warranty. This warranty is in lieu of any other warranty expressed or implied and NorthStar assumes no other responsibility or liability outside that expressed within this warranty.

Limited Warranty

NorthStar shall warranty any piece of equipment manufactured, or parts of equipment manufactured, to be free from defects in material or workmanship for a period of:

NorthStar Warranty		
Item #	Consumer Warranty Period	Commercial Warranty Period
110800, 110900, 1131	4 years from date of purchase by user	1 year from date of purchase by user

Engine Warranty		
Item #	Consumer Warranty Period	Commercial Warranty Period
110800, 110900, 1131	3 years from date of purchase by user	3 years from date of purchase by user

“Consumer use” means personal residential household use by a consumer. “Commercial use” means all other uses, including use for commercial, income producing or rental purposes or when purchased by a business.

This warranty applies to the original purchaser of the equipment (verification of purchase, in the form of a receipt, is the responsibility of the buyer), is non-transferable, and covers parts and labor. Parts will be replaced or repaired at no charge, except when the equipment has failed due to lack of proper maintenance. If a part is no longer available, the part may be replaced with a similar part of equal function. Any misuse, abuse, alteration or improper installation or operations will void warranty. Determining whether a part is to be replaced or repaired is the sole decision of NorthStar. NorthStar will not provide for replacement of complete products due to defective parts. Any costs incurred due to replacement or repair of items outside of a NorthStar approved facility is the responsibility of the buyer and not covered under warranty. Transportation costs to and from service center is the responsibility of the customer.

In addition to the normal warranty, NorthStar shall warrant any normal wear item from defects in material or workmanship for a period of 90 days from the date of purchase by user. Normal wear items include, but are not limited to, tires and filter elements.

This warranty specifically excludes the following; failure of parts due to damage caused by accident, fire, flood, windstorm, acts of God, applications not approved by NorthStar in writing, corrosion caused by chemicals, use of replacement parts which do not conform to manufacturer’s specifications, damage related to rodent and/or insect infestation and damage caused by vandalism. Additional exclusions: loss of running time, inconvenience, loss of income, or loss of use, including any implied warranty of merchantability of fitness for a specific use. Also, Outdoor Power Equipment needs periodic parts and service to perform well, and this warranty does not cover instances when normal use has exhausted the life of a component or the engine.

This warranty does not cover any personal injury or damage to surrounding property caused by failure of any part. Repair or replacement of parts does not extend the warranty period.

The engine warranty is covered under the terms and conditions as outlined by the engine manufactures warranty contained herein and is the sole responsibility of the engine manufacture. Normal engine maintenance such as spark plugs, air filters, adjustments, fuel system cleaning and obstruction due to build up is not covered by this NorthStar warranty.

Please fill in the following information and have it on hand when you call in on a warranty claim.

Customer Number: _____

Date of Purchase: _____

NorthStar Serial Number: _____

Item Number: _____

This page has intentionally been left blank.



Manufactured by
Northern Tool + Equipment Co., Inc.
Burnsville, MN 55306
NorthernTool.com