

DOSKO

M2965020D

ITEM NUMBER: 2965020

SERIAL NUMBER:

Owner's Manual

2965020 (3700LS-H)

**Instructions for Assembly, Testing, Operation,
Servicing, & Storage**

**Log Splitter: Outdoor hydraulic powered machine that
splits wood logs.**

WARNING

READ and UNDERSTAND this manual completely before using log splitter.

All operators of this equipment must read and completely understand all safety information, operating instructions, maintenance and storage instructions. Failure to properly operate and maintain the log splitter could result in serious injury to the operator or bystanders from moving parts that can crush or cut, flying objects, burns, fire or explosion, escaping high pressure hydraulic fluid, or carbon monoxide poisoning. In particular, be aware of the following hazards:

Crush and Cut Hazards

Moving parts can crush and cut hands and fingers. Keep hands clear of endplate, wedge, log strippers, and logs while splitting.

High Pressure Hydraulic Fluid Hazards

High fluid pressures and temperatures are developed in hydraulic log splitters. Hydraulic fluid escaping through even a pin-size hole opening can puncture skin and cause severe blood poisoning. Inspect hydraulic system regularly for possible leaks. Never check for leaks with your hand while the system is pressurized. Seek medical attention immediately if injured by escaping fluid.

Fire Hazards

- If your log splitter is intended for use near any ignitable forest, brush, or grassy covered land, the engine exhaust should be equipped with a spark arrestor.
- Keep a fire extinguisher with you, rated for ordinary combustibles and flammable liquids.

STOP!

ASSEMBLY REQUIRED: This product requires assembly before use. See "Assembly" section for instructions.
INSPECT COMPONENTS. Closely inspect upon receipt to make sure no components are missing or damaged. See "Assembly" section for instructions on whom to contact to report missing or damaged parts.
ADD ENGINE OIL and HYDRAULIC OIL BEFORE USING: This product is shipped without engine oil or hydraulic oil. DO NOT start log splitter before adding both oils. See "Assembly" and "Initial Unpacking & Set-up" sections for detailed instructions.

Any Questions, Comments, Problems or Parts Orders

Call your dealer or Dosko Customer Service 1-800-822-0295

Hazard Signal Word Definitions





	<p>This is the safety alert symbol. It is used to alert you to potential personal injury hazards. Obey all safety messages that follow this symbol to avoid possible injury or death.</p>
	<p>DANGER (red) indicates an imminently hazardous situation which, if not avoided, will result in death or serious injury.</p>
	<p>WARNING (orange) indicates a potentially hazardous situation which, if not avoided, could result in death or serious injury.</p>
	<p>CAUTION (yellow) indicates a potentially hazardous situation which, if not avoided, may result in minor or moderate injury.</p>
	<p>CAUTION (yellow) used without the safety alert symbol indicates a potentially hazardous situation which, if not avoided, may result in property damage.</p>

fig01453

About Your Log Splitter

About Your Log Splitter.....	4
Safety Label Locations	5
Machine Components Identification	7
Initial Set-up	8
Moving & Towing to the Job Site	10
Before Each Use:	
Step One: Inspection/Maintenance	13
Step Two: Fueling	15
Step Three: Work site Selection & Set-up.....	16
Splitting Operation	17
Storage	23
Periodic Maintenance	24
Troubleshooting.....	26
Specifications.....	27
Parts Breakdown – Exploded View.....	28
Summary of Important Safety Information for Operation.....	30
Disassembly Instructions.....	36
Assembly Instructions	37
Limited Warranty	39

About Your Log Splitter

Thank you for purchasing your Dosko log splitter!

About Your Log Splitter

This log splitter is a machine designed to split wood logs using a hydraulically powered moving wedge. The gasoline-powered engine is used to pressurize the system.

This log splitter model is capable of splitting logs up to 24" long and 16" in diameter

This log splitter is designed to split logs *lengthwise with the grain only*.

Your splitter can be used in either a vertical or horizontal splitting position:

- When the splitter is set up to operate in the horizontal splitting position, a log is placed on the horizontal beam and the wedge moves horizontally into the end of the log to split it.
- When the splitter is set up to operate in the vertical splitting position, the log is placed on the endplate, upright on its end, and the wedge moves down into the top of the log to split it.

The horizontal splitting position is used for lighter logs that can be easily loaded onto the beam.

The vertical splitting position is used for heavier logs that are difficult to load onto the beam.

The technical specifications for your log splitter are provided in the "Specifications" section of this manual.

WARNING

This log splitter uses a high-pressure hydraulic system to generate a very strong splitting force. **Read the manual completely** before using the machine to understand how to safely operate and maintain it.

Follow all safety precautions presented throughout this manual. A summary of important safety information can be found at the end of the manual.

Contact Dosko Customer Service at 1-800-822-0295 for any questions about the appropriate use of this log splitter or about optional accessories.

Attention: All Rental Companies and Private Owners who loan this equipment to others!

All persons to whom you rent/loan the log splitter must have access to and read this manual. Keep this owner's manual in the splitter's attached manual tube at all times and advise all persons who will operate the machine to read it. You must also provide personal instruction on how to safely operate the splitter and be available to answer any questions a renter/borrower might have.

Safety Label Location

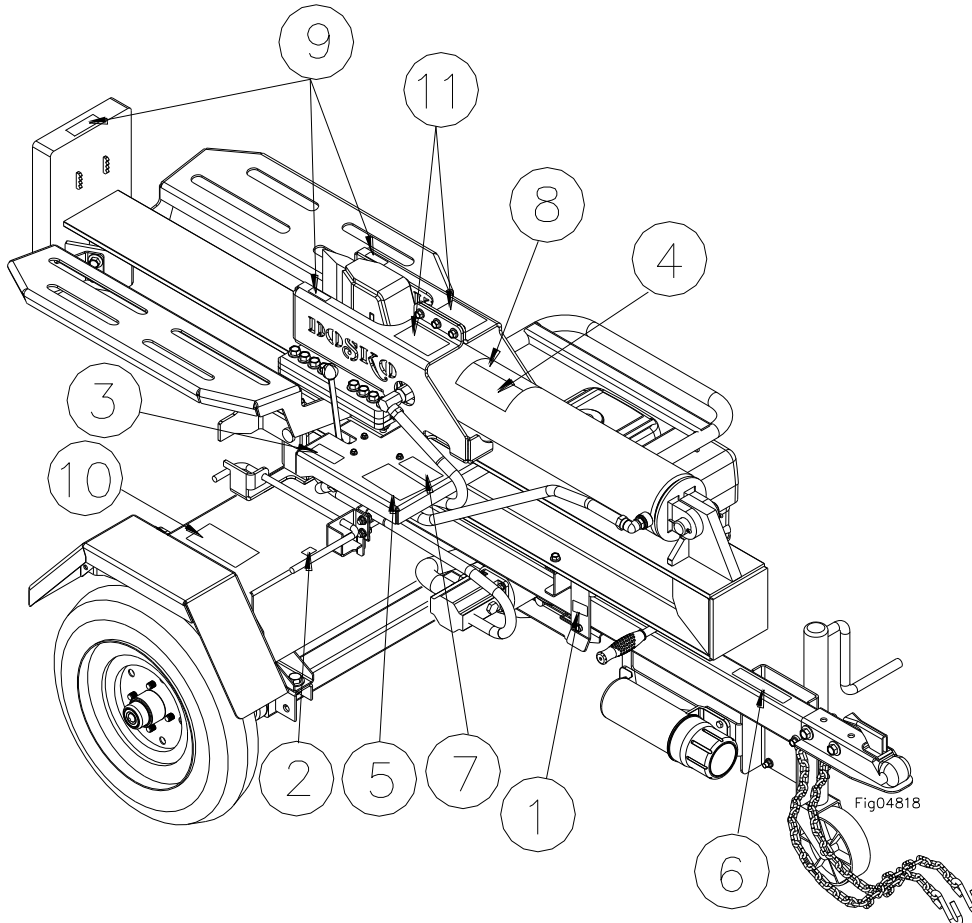

Ref#	Part #	Description	QTY
1	778597	Horizontal Lock	2
2	778714	Vertical Lock	1
3	778609	Split Control Lever Operation	1
4	778610	Log Splitter Warning	1
5	39259	Carbon Monoxide Warning	1
6	789236	Towing and Moving Instructions	1
7	777891	High Pressure Hydraulic Fluid Hazard	1
8	777890	Fire Hazard	1
9	787944	Pinch Point Warning	3
10	777887	Operating Instructions	1
11	778717	Log Stripper Warning	2

Always make sure safety labels are in place and in good condition. If a safety label is missing or not legible, order new labels or unsafe operation could result.

Safety Label Location

1

HORIZONTAL LOCK

PN 778597

2

VERTICAL LOCK

PN 778714

3

SPLIT CONTROL LEVER OPERATION

Split Log Neutral Return

4

WARNING

Moving parts can crush and cut. Pieces can fly out while splitting. Follow safety rules for operating the log splitter or serious injury could result.

- READ the Owner's Manual completely before operating.
- Only one person should operate the log splitter. If an assistant is helping to load logs, the operator should not actuate controls until the assistant is at least 10 ft away.
- Stay in the designated OPERATOR POSITION while actuating the controls.
- Split wood in direction of the grain only.
- Hold bark side of logs when loading.
- Keep hands away from wedge, endplate/ram, and partly split logs.
- Never leave log splitter unattended during operation.
- Stay off slopes and slippery surfaces.

See additional safety rules in the Owner's Manual.

PN 778610

5

WARNING

POISONOUS GAS

This product's use gives off carbon monoxide, an odorless gas that can kill you.

- ONLY use outdoors and away from air intakes.
- NEVER use inside homes, garages or sheds. EVEN IF you run a fan or open doors and windows.

See product manual for more details.

PN 39259

6

Moving log splitter by hand:

- Lock beam in horizontal position (tip-up models only).
- Lock towbar leg or jack in DOWN position.
- Do not attempt to move log splitter up or down slope by hand.

PN 78725

Towing log splitter:

- Latch coupler securely to class 2 or higher hitch with 2" ball.
- Lock towbar leg or jack in the UP position.
- Attach safety chains to tow vehicle.
- Close fuel shut-off valve on engine (if equipped).
- Do not tow faster than 45 mph on gravel or 55 mph on pavement.
- Higher speeds can cause loss of control.
- Check local, state, and federal requirements before towing on public roads.

MOVING/TOWING INSTRUCTIONS

7

WARNING

ESCAPING HIGH PRESSURE HYDRAULIC FLUID HAZARD

High fluid pressures and temperatures are developed in the hydraulic system. Hydraulic fluid escaping through even a pin-size hole opening can puncture skin and cause blood poisoning.

- Inspect hydraulic system regularly for leaks.
- Never check for leaks with your hand while system is pressurized.
- Seek medical attention immediately if injured by escaping fluid.

PN 778714

8

WARNING

FIRE HAZARD

Hot exhaust can ignite dry brush, trees, or grass.

- Equip engine with a spark arrestor if you will be using near ignitable forest, brush or grassy covered land.
- Keep a fire extinguisher on hand that is rated for ordinary combustibles & flammable liquids.

PN 77750

9

WARNING

PINCH POINT

Keep hands clear during operation.

787944

10

OPERATING INSTRUCTIONS

GENERAL

- Stay in the OPERATOR POSITION while actuating controls.
- Never actuate controls until the helper is 10ft away from log splitter, including any helpers assisting to load logs.
- Wear eye protection, hearing protection, snug fitting gloves, and safety shoes or heavy boots. No loose or dangling apparel.

SETTING UP

- Secure splitter for unintended movement.
- Place splitter in horizontal or vertical position.

SPLITTING LOG

- Position log on beam, against endplate.
- Move split control to extend wedge and split log.
- Release split control to stop wedge.
- Move split control to return wedge.
- Remove split wood from work area.

Operator Position - horizontal

Operator Position - vertical

PN 77750

11

LOG STRIPPER

RETRACT WEDGE TO REMOVE STUCK WOOD

WARNING

PINCH POINT

Keep hands clear of wedge and log stripper

Machine Component Identification

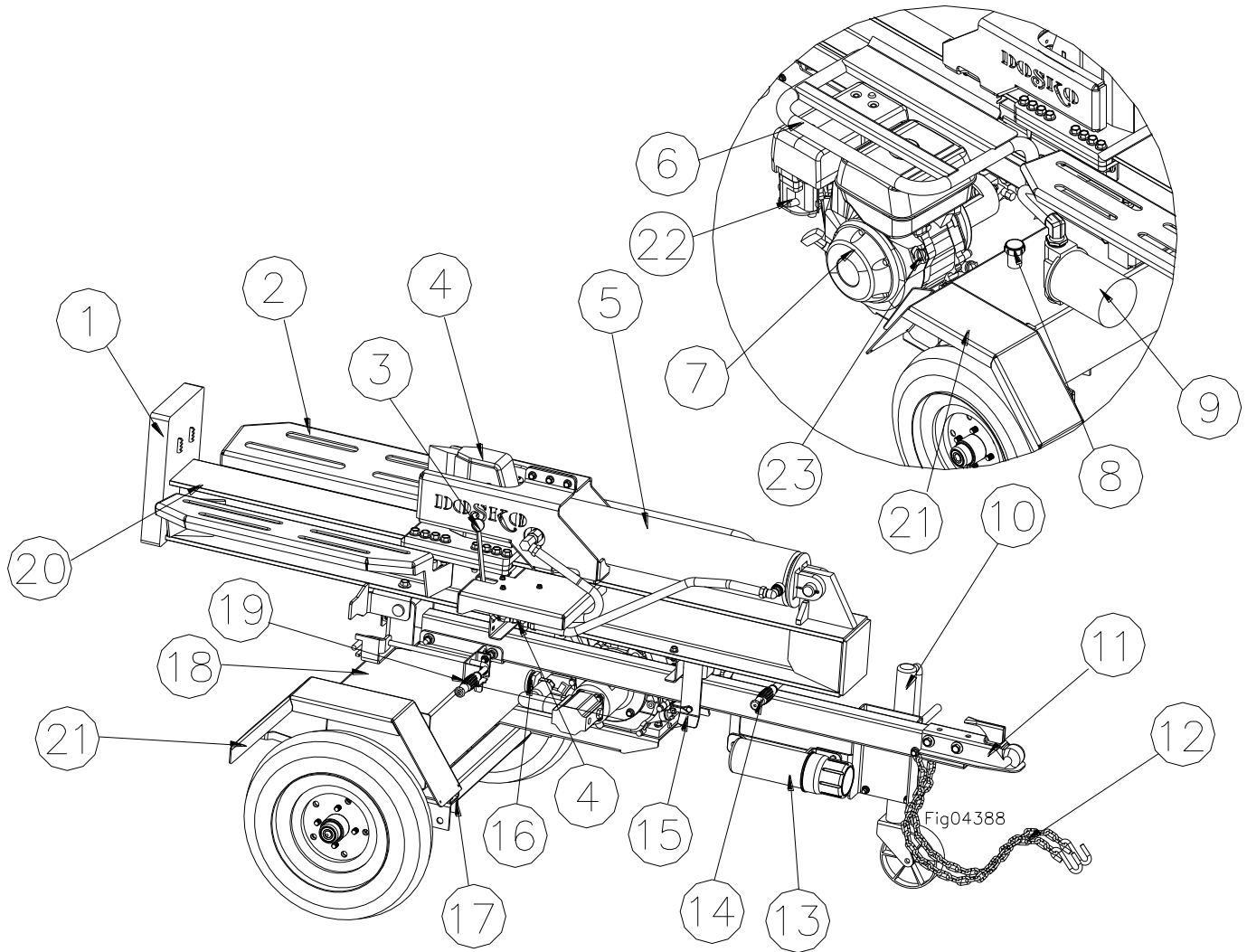

Ref #	Description
1	End Plate
2	Log Table
3	Split Control Lever
4	Wedge
5	Cylinder
6	Engine Guard
7	Engine
8	Hydraulic Oil Dipstick
9	Return Line Filter
10	Jack
11	2" Coupler
12	Safety Chains

Ref #	Description
13	Manual Tube
14	Lift Handle
15	Horizontal Lock
16	Suction Strainer
17	Magnetic Drain Plug
18	Hydraulic Tank
19	Vertical Lock
20	Beam
21	Fender
22	Fuel On/Off
23	Engine On/Off

Initial Set-up

WARNING

Carefully read and follow all instructions for initial assembly and set-up of this log splitter.

Failure to properly assemble and set up this equipment could result in serious injury to the user or bystanders, or cause equipment damage.

Step One: Assemble Log Splitter

Assemble your log splitter.

- Closely inspect all log splitter components.
- If you have missing components, contact Dosko Customer Service 1-800-822-0295.
- If you have damaged components, contact the Freight Company that delivered the unit and file a claim.

See the “Assembly” section of this manual – It will provide you with detailed instructions on:

- Inspecting shipped components and whom to contact if anything is missing or damaged.
- Assembly.
- Testing.

Step Two: Add Oil to Engine

Add oil to engine.

Using a funnel, add SAE 10W-30 oil up to the FULL mark on the dipstick. (See engine Owner’s Manual for oil capacity and location of fill cap.)

Step Three: Add Hydraulic Oil to Reservoir

1. Remove hydraulic oil dipstick.
2. Refer to the **Specifications** section for approximate hydraulic oil capacity.
3. Fill reservoir with 10 wt AW32, ASLE H-150, or ISO 32 oil. Use a funnel
4. Replace hydraulic oil dipstick and check that oil level reads full. Note: Do not thread in dipstick when checking oil level.
5. Start engine and use split control lever to extend and retract wedge 5 (five) times to remove air from the high pressure lines.
6. With wedge retracted, check oil level again. Fill if necessary.

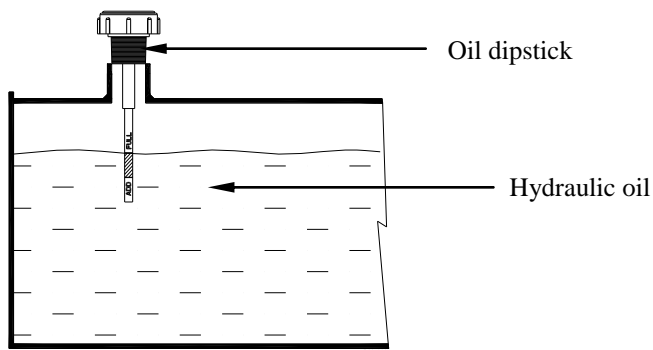

Note: If the log splitter will be run for long periods of time in outdoor temperatures above 70°F, we recommend changing the hydraulic oil to DEXTRON III.

Initial Set-up

Step Four: Check Hydraulic System

Check the hydraulic system carefully:

1. Visually inspect all hoses, tubing, clamps/fittings, pump, and cylinder for cracks, fraying, kinks, or other damage.
2. Check all components for oily residue, which may indicate a leak.

Do NOT operate the log splitter if there is any indication of damage or oily residue. Small leaks in hydraulic lines can cause severe injuries and can also be an indication of catastrophic failure in the near future. The life of hydraulic hoses may be from a few months to a few years, depending on use and storage patterns.

⚠️ WARNING: High fluid pressures and temperatures are developed in hydraulic log splitters. Hydraulic fluid escaping through a pin hole sized opening can burn or puncture skin, resulting in wounds that could cause blood poisoning, infection, disability, gangrene, amputation, or death. Therefore, the following instructions should be heeded at all times when inspecting or servicing the hydraulic components of the log splitter:

- Stop the engine, disconnect the spark plug, and move the split control lever back and forth to relieve pressure before changing or adjusting hydraulic system components such as hoses, tubing, fittings or other components.
- NEVER check for leaks with your hand. Leaks can be located by holding a piece of cardboard or wood (at least two feet long) with your hand at one end and passing the other end over the suspected area (wear eye protection). Look for discoloration of the cardboard or wood.
- NEVER adjust the pressure setting of the pump or valve.
- If injured by escaping fluid, no matter how small the wound is, see a doctor at once. A typical injection injury may be a small puncture wound that does not look serious. However, severe infection or reaction can result if proper medical treatment is not administered immediately by a doctor who is familiar with injection injuries.

⚠️ WARNING: NEVER remove the hydraulic oil fill cap when the engine is running or hot. Hot oil can escape causing severe burns. Allow log splitter to cool completely before removing hydraulic oil fill cap.

Moving & Towing to Job Site

WARNING

The log splitter is heavy. It can crush and cause serious injury if it rolls out of control or tips over. Follow the instructions below for safely moving and towing the log splitter.

Moving the log splitter

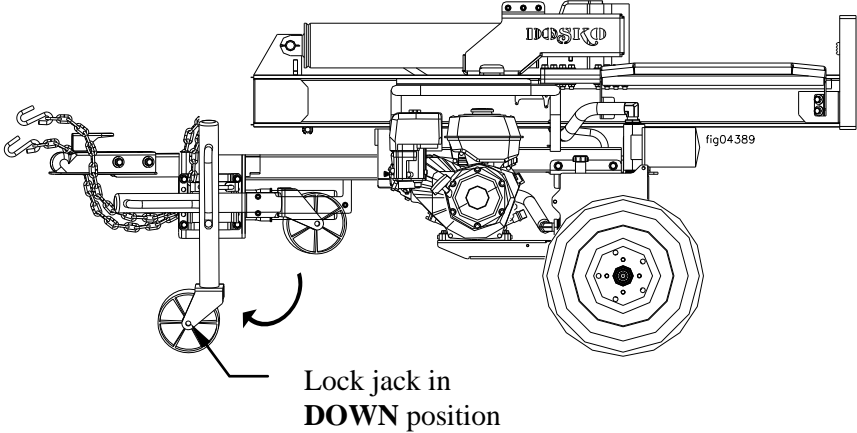
<p>1. Place in Horizontal Position</p>	<p>Make sure the log splitter is locked in the horizontal position with hitch pin before moving. NEVER move log splitter when it is in vertical configuration because it will be unstable and could tip.</p>
<p>2. Engine Off</p>	<p>IMPORTANT: Make sure log splitter engine is off. Never move the log splitter with its engine running.</p>
<p>3. Fuel Valve Off</p>	<p>Turn fuel valve off to prevent carburetor flooding and reduce the chance of fuel leakage.</p>
<p>4. Lock Jack in Down Position</p>	<p>Lock jack in down position before you move the log splitter.</p> 
<p>5. Move Log Splitter to Work Site or Tow Hitch</p>	<p>Roll the splitter by hand either directly to chosen work site or to vehicle hitch for towing. (See instructions on p. 16 on selecting a work site.)</p> <p><u>Important Safety Instructions:</u></p> <ul style="list-style-type: none"> • Hills. Do not move the log splitter up or down hills by hand -- use a towing vehicle. • No riding. Never allow anyone to sit or ride on the log splitter. • No cargo. Never transport cargo or wood on the log splitter.

Moving & Towing to Job Site

Towing:

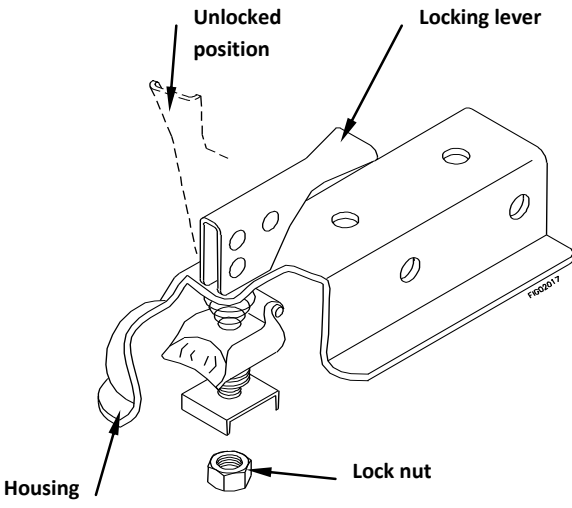
1. Read Instructions	Review towing safety instructions in your vehicle manual.
2. Check Tires	<p>Make sure tires are fully inflated and in good repair. See tire sidewall for recommended tire pressure.</p> <p>⚠️WARNING:</p> <ul style="list-style-type: none"> • Do not over-inflate tires. Serious injury can occur if tire explodes. • When seating a bead after repair, do not exceed 30 PSI. Pressures higher than 30 PSI can cause the tire and wheel to rupture and explode.
4. Turn Engine Off	<p>Turn engine off. Never move the log splitter with the engine running.</p>
5. Turn Fuel Valve Off	<p>Turn fuel valve off. This will prevent carburetor flooding and reduce the chance of fuel leakage.</p>
6. Attach to Hitch (2" ball)	<p>Attach log splitter to vehicle hitch</p> <ol style="list-style-type: none"> 1. Attach log splitter's coupler to a class 2 or higher hitch with 2" ball (only). 2. Adjust coupler to ball by raising locking lever and turning lock nut with fingers. 3. Proper adjustment is obtained when coupler is as tight as possible on ball and locking lever can still be opened and closed. 4. Lock lever closed to secure the attachment. An optional locking pin or padlock may be inserted in the locking lever hole for extra security. <div style="text-align: center; margin-top: 10px;">  </div>
6. Attach Safety Chains	<p>Attach safety chains.</p> <ol style="list-style-type: none"> 1. Two safety chains must be used while towing. 2. Cross safety chains under the coupler allowing only enough slack for vehicle turns.

Moving & Towing to Job Site

7. Put Jack Up

To provide adequate ground clearance while towing, secure the jack in the “UP” position.

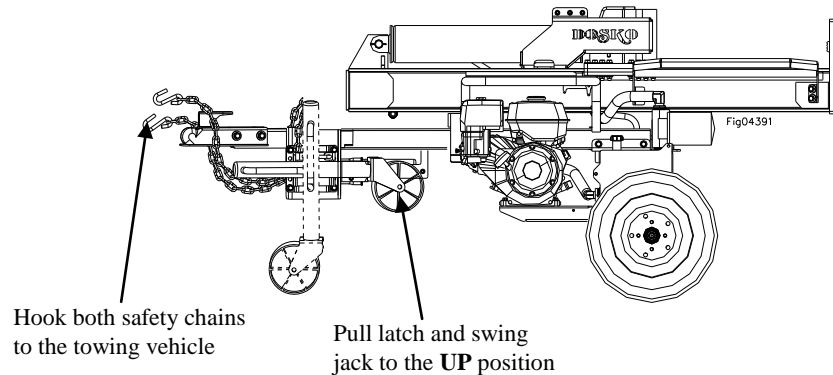

8. Tow to Desired Location

Tow log splitter carefully to desired work site.

(See instructions on pg.16 on selecting an appropriate work site.)

Important safety instructions:

- **Added length.** Be aware of the added length of the splitter.
- **Speed limit.** Never tow this log splitter over 55 MPH on pavement and 45 MPH on gravel. Faster speeds may result in loss of control.
- **Rough terrain.** Drive slowly and take extra caution when traveling over rough terrain.
- **On public roads.** If towing on a public road, make sure to comply with all local, state, and federal towing requirements. It is the sole responsibility of the purchaser to obtain licensing, trailer lights, safety chains or signage, as needed to comply.
- **Unattended.** Turn off the towing vehicle before leaving the splitter unattended.

Under the influence. Never tow or operate this splitter while under the influence of alcohol, drugs, or medication.

9. Lower Jack Down & Unhitch

Lower the jack down and then unhitch from vehicle.

NEVER operate log splitter while it is attached to the vehicle.

1. Lower the jack and use it to lift the coupler slightly to assist in unhitching.
2. Unhitch from vehicle.

Before Each Use – Inspection / Maintenance

Step One: Inspect and maintain log splitter before each use.

If the log splitter has been used previously, it must be inspected and maintained BEFORE EACH SUBSEQUENT USE.

WARNING

ALWAYS shut off the engine, disconnect the spark plug, and relieve system pressure before inspecting, cleaning, adjusting, or repairing the splitter. Relieve system pressure by moving the split control lever back and forth several times.

Important:

If a part needs replacement, only use parts that meet the manufacturer’s specifications. Replacement parts that do not meet specifications may result in a safety hazard or poor operation of the log splitter.

1. Engine off / relieve hydraulic pressure	Perform all inspections/repairs with the engine off and hydraulic system pressure relieved. <ol style="list-style-type: none"> 1. Make sure engine is off and cool. 2. Disconnect the spark plug 3. Relieve all hydraulic system pressure by moving the split control lever back and forth several times.
2. Remove debris	Remove debris from engine, muffler, and moving parts. <ol style="list-style-type: none"> 1. <u>Engine debris.</u> Debris on a hot engine can be a fire hazard. Clean debris and chaff from engine cylinder head, cylinder head fins, blower housing rotating screen, and muffler areas. Avoid contact with hot muffler. 2. <u>Other debris.</u> Debris on moving parts can cause excess wear. Clear debris from the beam, wedge, log stripper, and end plate.
3. Fuel tank / lines	Check fuel tank and fuel lines for leaks. Any fuel leak is a fire hazard. Fix any fuel leaks before starting engine.
4. Mechanical parts	Check to be sure all nuts and bolts are tight to make sure the log splitter is in safe working condition. Refer to Bolt Torque Chart on pg. 25. Apply grease to beam where the wedge travels.

Apply grease to the top of the beam and underneath the edge of the beam

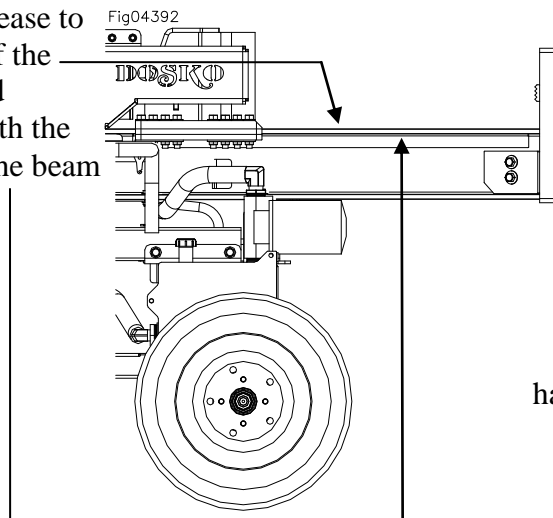

Some features have been hidden for clarity.

Before Each Use – Inspection / Maintenance



5. Hydraulic system	<p>Check the hydraulic system carefully:</p> <ol style="list-style-type: none"> 1. Visually inspect all hoses, tubing, clamps/fittings, pump, and cylinder for cracks, fraying, kinks, or other damage. 2. Check all components for oily residue, which may indicate a leak. <p>Do NOT operate the log splitter if there is any indication of damage or oily residue. Small leaks in hydraulic lines can cause severe injuries and can also be an indication of catastrophic failure in the near future. The life of hydraulic hoses may be from a few months to a few years, depending on use and storage patterns.</p> <p>⚠️ WARNING: High fluid pressures and temperatures are developed in hydraulic log splitters. Hydraulic fluid escaping through a pin hole sized opening can burn or puncture skin, resulting in wounds that could cause blood poisoning, infection, disability, gangrene, amputation, or death. Therefore, the following instructions should be heeded at all times when inspecting or servicing the hydraulic components of the log splitter:</p> <ul style="list-style-type: none"> • Stop the engine, disconnect the spark plug, and move the split control lever back and forth to relieve pressure before changing or adjusting hydraulic system components such as hoses, tubing, fittings or other components. • NEVER check for leaks with your hand. Leaks can be located by holding a piece of cardboard or wood (at least two feet long) with your hand at one end and passing the other end over the suspected area (wear eye protection). Look for discoloration of the cardboard or wood. • NEVER adjust the pressure setting of the pump or valve. • If injured by escaping fluid, no matter how small the wound is, see a doctor at once. A typical injection injury may be a small puncture wound that does not look serious. However, severe infection or reaction can result if proper medical treatment is not administered immediately by a doctor who is familiar with injection injuries.
6. Hydraulic oil level	<p>Check dipstick to make sure hydraulic oil level is to the fill line with cylinder retracted. Fill as needed. Note: Do not thread in the oil dipstick when checking hydraulic oil level.</p> <p>⚠️ WARNING: NEVER remove the hydraulic oil fill cap when the engine is running or hot. Hot oil can escape causing severe burns. Allow log splitter to cool completely before removing hydraulic oil fill cap.</p>
7. Engine	Inspect and perform engine maintenance as directed in the engine manual.
8. Spark arrestor muffler	If the engine is equipped with a spark arrestor muffler, clean and inspect it regularly (follow spark arrestor manufacturer’s service instructions). Replace if damaged.
9. Tires	<p>Make sure tires are fully inflated and in good repair if you will be towing the splitter.</p> <p>See tire sidewall for recommended tire pressure.</p> <p>⚠️ WARNING:</p> <ul style="list-style-type: none"> • Do not over-inflate tires. Serious injury can occur if tire explodes. • When seating a bead after repair, do not exceed 30 PSI. Pressures higher than 30 PSI can cause the tire and wheel to rupture and explode.
10. Shields / guards	Replace all guards and shields after servicing the log splitter.

Before Each Use – Fueling

Step Two: Fueling

WARNING

Gasoline is highly flammable and explosive. You can be burned or seriously injured when handling fuel. Use extreme care when handling gasoline.

1. Engine off / cool	<p>The engine must be off and allowed to cool at least two minutes before adding fuel.</p> <p> WARNING: A running engine is hot enough to ignite fuel. Never add fuel or remove gas cap if engine is running or still hot.</p>
2. Outdoor location	<p>Fill fuel tank outdoors – never indoors.</p> <p> WARNING: Gasoline vapors can ignite if they collect inside an enclosure. Explosion can result.</p>
3. Remove gas cap	Remove engine gas cap.
4. Add gasoline	<p>Add gasoline through fill opening from an UL-approved container.</p> <p><u>Important Safety Instructions:</u></p> <ul style="list-style-type: none"> • Use approved container. NEVER pump fuel directly into engine at gas station. Static charge can build and ignite fuel. Use a UL approved fuel container to transfer gas to the engine. • Don't overfill. DO NOT overfill the gas tank. Allow at least 1/2" of empty space below the fill neck to allow for fuel expansion • Heat / flames / sparks. Stay away from sources of heat, flame, or sparks while adding fuel. <div style="text-align: center;">  </div>
5. Spills / splashes	<p>Clean up fuel spills /splashes immediately.</p> <ol style="list-style-type: none"> 1. Move log splitter away from spilled fuel on the ground. 2. Wipe fuel off engine and wait 5 minutes for excess fuel to evaporate before starting engine. 3. Gas soaked rags are flammable and should be disposed of properly. 4. If gasoline is spilled on your skin or clothes, change clothes and wash skin immediately.
6. Replace gas cap	Replace gas cap securely before starting engine.
7. Gasoline storage	Store extra gasoline in a cool, dry place in an UL approved, tightly sealed container.

Before Each Use – Work Site Selection & Set-Up

Step Three: Work site selection and log splitter set-up



WARNING

It is important to select an appropriate work site and properly set up the log splitter in order to minimize the risk of slips and falls, equipment rolling or tipping over, carbon monoxide poisoning, and accidental fires.

1. Select location	<p>Select an appropriate location for operating the log splitter.</p> <p><u>Requirements:</u></p> <ol style="list-style-type: none"> 1. Dry, level surface with good footing. Stay clear of areas with mud, ice, tall grass, weeds, or brush. 2. Outdoors, away from air intakes. <p>⚠️ DANGER: The running engine gives off carbon monoxide, a poisonous gas that can kill you. You CANNOT smell it, see it, or taste it.</p> <ul style="list-style-type: none"> • ONLY run log splitter <u>OUTDOORS</u> and away from air intakes. NEVER run log splitter inside homes, garages, sheds, or other buildings or semi-enclosed spaces. These spaces can trap poisonous gases, EVEN if you run a fan or open windows. • If you start to feel sick, dizzy, or weak while using the log splitter, shut off the engine and get to fresh air RIGHT AWAY. See a doctor. You may have carbon monoxide poisoning.
2. Fire precautions	<p>Take the following precautions against fire:</p> <ol style="list-style-type: none"> 1. <u>IMPORTANT:</u> If your splitter will be used near any unimproved forest, brush, or grassy covered land, <i>then engine must be equipped with a <u>spark arrestor.</u></i> 2. Make sure you comply with applicable local, state and federal codes. 3. Keep a fire extinguisher available (classified for both ordinary combustibles & flammable liquids) as a precautionary measure when operating the log splitter in dry areas.
3. Position 7' from any combustibles or flammable liquids	<p>Position splitter at least 7 ft. from combustible objects during operation.</p> <p>Hot exhaust fumes from splitter engine could cause fire. Also, hydraulic oil leaking or spraying on hot engine can ignite.</p>
4. Block Wheels	<p>Block wheels to prevent unintended movement of the log splitter.</p>

Splitting Operation



Before starting the log splitter, review the following instructions and safety information for safe operation. Failure to follow these rules may result in serious injury to the operator or bystanders from moving parts that crush, cut, or entangle; from flying objects, burns, fire, falling or tripping; or from carbon monoxide poisoning.

General safety information

- **Read manual.** Do not allow anyone to operate the log splitter who has not read the Owner's Manual or has not been instructed on the safe use of the splitter. The log splitter owner should instruct all operators in safe log splitter operation.
- **Age restrictions.** Never allow anyone under 16 years old to operate the log splitter. Children 16 years and older must be trained and supervised by a trained adult.
- **Intended use.** Log splitters should only be used for splitting wood logs, lengthwise with the grain. Do not use for other purposes as unforeseen hazards may result.
- **Modifications.** Never modify or alter the log splitter in any way. Modifications can create serious safety hazards and will void the warranty:
 - **Attachments.** Never add attachments to the splitter, except for authorized accessories supplied by the manufacturer with instructions for safe installation and use.
 - **Engine speed.** The maximum engine speed is preset at a safe limit. Never attempt to modify the engine speed setting to run at a higher speed.
 - **Fuel/exhaust system.** NEVER modify or add to the exhaust system, fuel tanks, or fuel lines. Fire can result.
 - **Remote control.** NEVER attach a rope, cable, or other remote device to the splitting control.
 - **Splitting wedge.** NEVER attempt to change the height or speed of the splitting wedge.
 - **Pressure setting.** NEVER increase the pressure setting of the pump or control valve.
- **Safety equipment / controls.** Always operate the log splitter with all safety equipment in place and in good working order, and all controls properly adjusted for safe operation.
- **Know how to stop.** Be thoroughly familiar with all controls and with the proper use of the equipment. Know how to stop the log splitter and relieve system pressures quickly if needed.
- **Operating speed.** Always operate the log splitter at the manufacturer's recommended speed. The maximum speed of the engine, pump and wedge are preset within safe limits.
- **Daylight only.** Only use the log splitter in daylight so you can see what you are doing.
- **Smoking / sparks.** Never smoke while operating the log splitter, and never operate near sources of sparks or flames.
- **Under the influence.** Never operate, or let anyone else operate, the log splitter while under the influence of alcohol, drugs, or medication.
- **Unattended.** Never leave the machine unattended while the engine is running.
- **Refueling.** Never refuel the engine until it has cooled at least two minutes.
- **Adjusting / repairing.** Always make sure the engine is off before cleaning, repairing or adjusting the splitter, except as recommended by the manufacturer. In addition, disconnect the spark plug and move all control handles back and forth to relieve system pressure *before changing or adjusting hydraulic system components* such as hoses, tubing, fittings or other components.
- **Replace labels.** Always make sure safety labels are in place and in good condition. If a safety label is missing or not legible, order new labels because unsafe operation can result. Call 1-800-822-0295 to order new safety labels.

Splitting Operation

b) Set to
Vertical
position

- 1) Pull out horizontal lock catch pin, then grasp lifting handle and lift beam until it rotates into vertical position.

⚠ WARNING: Crush hazard. The beam is heavy – do not let it just drop. It could crush fingers or cause damage to the splitter.

Vertical Splitting Position

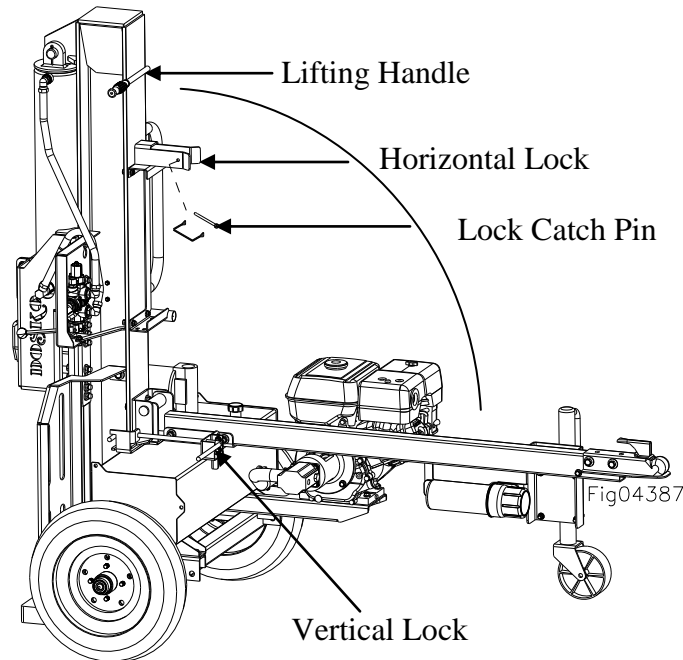

- 2) Lock in vertical position by rotating vertical lock.

To return to horizontal position, unlock vertical position, grasp lifting handle and lower beam carefully in a controlled manner until it rests on the tow bar, lock beam in the horizontal position with catch pin.

4. Start engine

Start the engine.

See the engine owner's manual for engine starting instructions.

Note:

- a) Make sure the hydraulic oil is above 10°F before starting the engine. Cold hydraulic oil can damage the hydraulic pump.
- b) If outdoor air temperature is below 32°F, allow log splitter to warm up by extending and returning the wedge several times before splitting wood.

⚠ WARNING:

Burns. To avoid burns, stay clear of hot muffler if you are starting a warm engine.

Carbon monoxide. The running engine gives off carbon monoxide, a poisonous gas that can kill you. You CANNOT smell it, see it, or taste it. If you start to feel sick, dizzy, or weak while using the log splitter, shut off the engine and get to fresh air RIGHT AWAY. See a doctor. You may have carbon monoxide poisoning.

Other exhaust dangers. Engine exhaust, some of its constituents, and certain vehicle components contain or emit chemicals known to the State of California to cause cancer, birth defects, or other reproductive harm. Avoid inhalation of exhaust.

Splitting Operation

5. Load log

Load log onto beam between the wedge and an endplate, cut edge against the endplate - positioned for a lengthwise cut.

Notes:

- The log splitter is designed only for cutting lengthwise with the grain, NOT for cutting across the grain.
- This log splitter is designed for cutting logs only up to 24" long and 16" in diameter, lengthwise with the grain only. Larger diameter logs could get stuck on the wedge and longer logs will not fit on the beam.

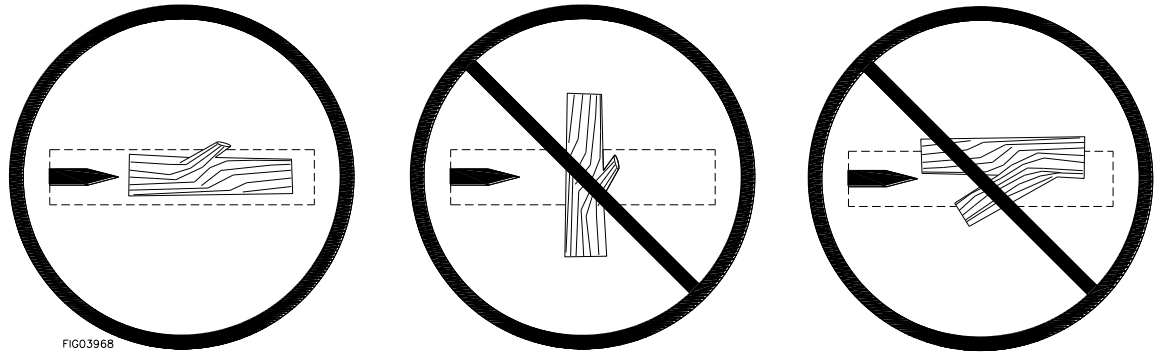

Correct Log Orientation

Incorrect Log Orientation

⚠ WARNING: ALWAYS keep hands and feet away from the wedge and partially split logs while loading, operating and unloading the log splitter.

Important safety instructions:

- **Hold bark side.** Hold the bark side of logs when loading or positioning, never the ends. Never place your hands or any part of your body between a log and any part of the log splitter. NEVER place hands on log while splitting.
- **Wedge moving.** NEVER load or unload logs while the wedge is moving.
- **Straddling / reaching across.** Never straddle, reach across, or step over the beam while the engine is running. You could trip, actuate the controls, and get seriously injured.
- **Unsplit log pile.** Do not pile logs to be split in a place that will make you reach across the log splitter in order to load them.
- **Square log ends.** Logs that are not cut square can slide out while splitting and become a safety hazard or cause excessive force to log splitter components. Use a chainsaw to cut logs square on each end before attempting to split them.
- **Single log.** Never attempt to split more than one log at a time. Pieces of log can unexpectedly be thrown from the machine causing serious injury.
- **Split along grain.** Do not use the log splitter to split logs across the grain. Doing so will damage the log splitter and could also cause pieces of log to be thrown, injuring the operator or bystanders
- **Forked logs.** Splitting forked logs can cause damage to the log splitter. Trim the forked log with a chain saw prior to splitting the log.
- **Changing splitting position.** Do not change splitting positions (horizontal/vertical) with the engine running. You may contact the muffler and receive serious burns. Be careful to avoid contact with hot muffler even after the engine is turned off.

Splitting Operation

6. Extend wedge

Move Split Control Lever toward endplate to extend wedge and split log.

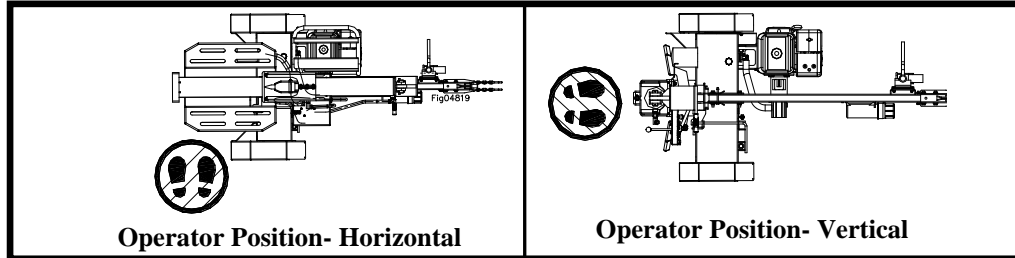
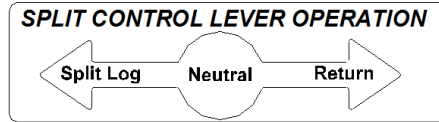

Important safety instructions:

- **Operator position.** ALWAYS operate the log splitter from the manufacturer's indicated OPERATOR POSITION. (See diagram above.) Other positions are unsafe because they can increase the risk of injury from crushing, cutting, flying objects, or burns.
- **Remove hands.** Remove both hands from log before activating Split Control Lever.
- **Hand activate.** Use only your hand to operate the Split Control Lever. Never use any other body part, or a rope, cable, or other remote device to actuate the control.
- **Second person.** Many accidents occur when there is more than one person involved in loading and operating the log splitter. Only one person should operate the controls. *If a second person is assisting in loading logs, the operator must NEVER actuate the Split Control Lever until the assistant and all bystanders are at least 10 feet away. NEVER allow an assistant to hold the log in place while the operator actuates the Split Control Lever.*

7. Stop wedge

Release Split Control Lever to stop wedge movement when log is split.

⚠ WARNING: Cracks in logs can close quickly and pinch fingers. Keep fingers away from any cracks that open in partially split logs.

SPLIT CONTROL

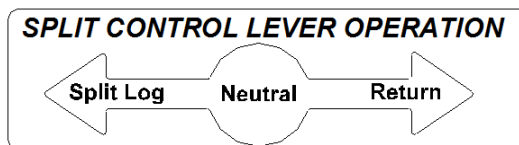

Splitting Operation

8. Important STUCK LOG procedure

If a log does not split completely and becomes stuck on the wedge, follow the instructions below to remove the log.

A log can become stuck to the wedge if the wedge becomes embedded in the log and the log doesn't split and separate. This can happen if the log is too stringy or tough to split completely.

A stuck log will move back with the wedge on the initial attempt to retract the wedge. If this happens, retract the wedge completely to allow the splitter to strip the log from the wedge. Keep hands clear of log, wedge, and log stripper while wedge is retracting.

⚠ WARNING: NEVER attempt to remove a stuck log by:

- Modifying the splitter.
- Adding attachments to the splitter.

Personal injury could result from log or metal pieces flying out at high speed toward the operator or bystanders, or the splitter could become damaged.

9. Return wedge

Move Split Control Lever away from end plate to return wedge.

Once the control valve is actuated in the return direction, the wedge is designed to keep returning by itself completely and then stop automatically.

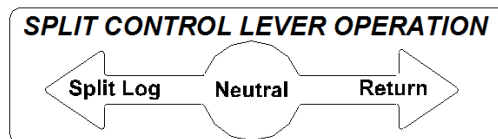

⚠ WARNING:

Stay clear while the wedge is returning. It is still powerful enough on the return stroke to cause serious injury.

10. After use

1. Turn off engine.

2. Remove engine debris.

Debris on a hot engine can be a fire hazard. After the engine is off, clean debris and chaff from engine cylinder head, cylinder head fins, blower housing rotating screen, and muffler areas.

⚠ WARNING: Avoid contact with hot muffler.

3. Return to horizontal position.

If in the vertical position, return log splitter to the horizontal position for greater stability and to prepare for transportation. Avoid contact with hot muffler.



Any Questions, Comments, Problems or Parts Orders
Call your dealer or Dosko Customer Service 1-800-822-0295

Storage

WARNING

Gasoline vapors can ignite and cause a fire. Select a well-ventilated storage area away from sources of heat, flame, or sparks.

Follow the instructions below for storing your log splitter between uses:

1. Retract cylinder	Retract the wedge completely to the hitch end of the log splitter to keep the rod protected from corrosion.
2. Cool	<p>Allow the machine to cool 5 minutes before storing.</p> <p> WARNING: A hot engine can be a fire hazard.</p>
3. Wipe with oily rag	Wipe the wedge with an oily rag to prevent corrosion.
4. Engine manual	<p>Refer to the engine manual for proper engine storage instructions.</p> <p>CAUTION: Gasoline will oxidize and deteriorate in storage. Old gasoline in the engine will cause hard starting and leave gum deposits that can clog the fuel system. Deterioration problems may occur within a few months, or even less if gasoline was not fresh when you filled the fuel tank.</p> <p>Short-Term Storage:</p> <ol style="list-style-type: none"> 1. Consider adding a fuel stabilizer to extend fuel storage life. 2. Leave the fuel valve lever in the OFF position to reduce the possibility of fuel leakage. <p>Long Term Storage: (between infrequent uses and at end of season) Drain the fuel tank and carburetor as instructed in the engine owner's manual.</p> <p><u>Important Safety Instructions:</u></p> <ul style="list-style-type: none"> • Always drain fuel from tank in outdoor, well-ventilated area. • Stay away from sources of heat, flame, or sparks while handling fuel. • Clean up fuel spills/splashes immediately.
5. Splitter storage location	<p>Store the log splitter in a location away from corrosive material, sources of heat, open flames, sparks or pilot lights.</p> <p> WARNING: Never store log splitter inside where there is a source of heat or an open flame, spark, or pilot light – such as water heaters, space heaters, furnaces, clothes dryers, or other gas appliances. Even if the log splitter's gas tank is empty, residual gasoline vapors could ignite.</p> <p>NOTE: Do not store the log splitter near fertilizer or any other corrosive material.</p>
6. Gasoline storage	<p>Store gasoline in a cool, dry place in an UL approved, tightly sealed container.</p> <p> WARNING: Gasoline vapors can ignite if they collect inside an enclosure and explosion can result.</p>

Periodic Maintenance



In addition to the maintenance performed with each use, periodic maintenance should also be performed according to the following schedule.

 **WARNING**

ALWAYS shut off the engine, disconnect the spark plug, and relieve system pressure before cleaning, adjusting, or repairing the splitter. Relieve system pressure by moving Split Control Lever back and forth several times.

IMPORTANT:

If a part needs replacement, only use parts that meet the manufacturer’s specifications. Replacement parts that do not meet specifications may result in a safety hazard or poor operation of the log splitter

1. Engine Maintenance	Perform engine maintenance as specified in the engine owner’s manual.
2. Hydraulic Oil and Return Line Filter Change	<p>Change hydraulic oil annually / 500 hours.</p> <p> WARNING: High fluid pressures and temperatures are developed in hydraulic log splitters. Hydraulic fluid escaping through a pin hole sized opening can burn or puncture skin, resulting in wounds that could cause blood poisoning, infection, disability, gangrene, amputation, or death. Therefore, the following instructions should be heeded at all times when inspecting or servicing the hydraulic components of the log splitter:</p> <ul style="list-style-type: none"> ○ NEVER check for leaks with your hand. Leaks can be located by holding a piece of cardboard or wood (at least two feet long) with your hand at one end and passing the other end over the suspected area (wear eye protection). Look for discoloration of the cardboard or wood. ○ NEVER adjust the pressure setting of the pump or valve. ○ If injured by escaping fluid, no matter how small the wound is, see a doctor at once. A typical injection injury may be a small puncture wound that does not look serious. However, severe infection or reaction can result if proper medical treatment is not administered immediately by a doctor who is familiar with injection injuries. <ol style="list-style-type: none"> 1. Use 10 wt AW32, ASLE H-150, or ISO32 oil. 2. Relieve hydraulic system pressure by moving the splitter control lever back and forth several times. 3. Remove hydraulic oil fill cap. <ul style="list-style-type: none">  WARNING: NEVER remove the hydraulic oil fill cap when the engine is running or hot. Hot oil can escape causing severe burns. Allow log splitter to cool completely before removing hydraulic oil fill cap. 4. Remove the drain plug to drain the oil. 5. Remove any debris stuck to magnetic drain plug. 6. Fill with the specified quantity. 7. Replace dipstick and check that oil level reads full (before starting engine and checking oil level again). Note: Do not thread in the oil dipstick when checking the hydraulic oil level. 8. Dispose of used oil at an oil-recycling center. Used hydraulic oil is hazardous waste.

Periodic Maintenance

Change return line filter after the first 50 hours of operation, and every 250 hours thereafter.

1. Use a 788283-1 return line filter.
2. Shut down the engine on the Log Splitter.
3. Relieve hydraulic system pressure by moving the splitter control lever back and forth several times.
4. Unthread the canister and discard it along with the accompanying seal. Note: A strap wrench may be required. Not provided.

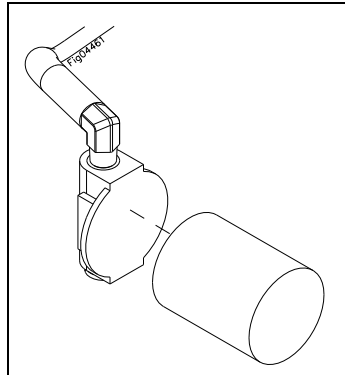

5. Apply a small amount of lubricant to the new canister seal.
6. Install the new canister and hand tighten 3/8 to 1/2 turn after gasket makes contact with head.

3. Spark arrestor muffler

If the engine is equipped with a spark arrestor muffler, clean and inspect it regularly (follow manufacturer's service instruction). Replace if damaged.

Bolt Torque Chart

Bolt Size	Location	Bolt Grade	Lubricated Nut	Torque, ft-lbs.
1/2-13	Wedge to Keepers	8	Yes	80
1/2-13	Tongue to Coupler	5	Yes	57
5/8-11	Suspension to Hyd. Tank	5	Yes	113
1/2-13	Tongue to Tank	5	Yes	57
3/8-16	Common	5	No	34
1/2-13	Common	5	No	83
Lug Nuts	Wheel Hub to Wheel	8	No	90

Troubleshooting

WARNING

Before troubleshooting or attempting to service, read the following safety instructions to avoid serious injury to the operator or bystanders from moving parts that can crush or cut, burns, fire or explosion, or escaping high pressure hydraulic fluid.

Important Safety Instructions

1. **Engine off.** Always make sure the engine is off before cleaning, repairing or adjusting the splitter, except as recommended by the manufacturer.
2. **Hydraulic safety.** High fluid pressures and temperatures are developed in hydraulic log splitters. Hydraulic fluid escaping through a pin hole sized opening can burn or puncture skin, resulting in wounds that could cause blood poisoning, infection, disability, gangrene, amputation, or death. Therefore, the following instructions should be heeded at all times when inspecting or servicing the hydraulic components of the log splitter:
 - Stop the engine, disconnect the spark plug, and move split control lever back and forth to relieve pressure before changing or adjusting hydraulic system components such as hoses, tubing, fitting or other components.
 - Do not remove the hydraulic oil fill cap when the engine is running. Hot oil can escape causing severe burns. Allow log splitter to cool completely before removing hydraulic oil fill cap.
 - Do not adjust the pressure setting of the pump or valve.
 - NEVER check for leaks with your hand. Leaks can be located by holding a piece of cardboard or wood (at least two feet long) with your hand at one end and passing the other end over the suspected area (wear eye protection). Look for discoloration of the cardboard or wood.
 - If injured by escaping fluid, no matter how small the wound is, see a doctor at once. A typical injection injury may be a small puncture wound that does not look serious. However, severe infection or reaction can result if proper medical treatment is not administered immediately by a doctor who is familiar with injection injuries.

Problem	Solution
Cylinder rod will not move	Solution: A,D,E,H,J
Slow cylinder shaft speed when extending or retracting	Solution: A,B,C,H,I,K,L
Wood will not split or splits extremely slowly	Solution: A,B,C,F,I,K
Engine bogs down during splitting	Solution: G
Engine stalls under low load condition	Solution: D,E

Cause	Solution
A – Insufficient oil to pump	Check oil level in reservoir
B – Air in oil	Check oil level in reservoir
C – Excessive pump inlet vacuum	Check pump inlet hose for blockage or kinks
D – Blocked hydraulic lines	Flush and clean the splitter hydraulic system
E – Blocked control valve	Flush and clean the splitter hydraulic system
F – Low control valve setting	Adjust control valve with a pressure gauge
G – High control valve setting	Adjust control valve with a pressure gauge
H – Damaged control valve	Return control valve for authorized repair
I – Internal control valve leak	Return control valve for authorized repair
J – Damaged cylinder piston	Return cylinder for authorized repair
K – Internally damaged cylinder	Return cylinder for authorized repair
L – Drawing air through suction line	Check and tighten hose clamps on suction hose

Any Questions, Comments, Problems or Parts Orders
Call your dealer or Dosko Customer Service 1-800-822-0295

Specifications

Maximum Pressure	3500 PSI
Maximum Flow	16 GPM
Hydraulic Fluid Capacity.....	12 Gallons
Hydraulic Fluid Type.....	*10 wt AW32, ASLE H-150, or ISO32
Engine Size.....	270 cc
Coupler Size.....	2"
Maximum Towing Speed.....	55 MPH pavement, 45 MPH gravel
Maximum Log Length	24"
Maximum Log Diameter.....	16"
Hydraulic Cylinder Bore	5"
Hydraulic Cylinder Stroke	24"
Spark Arrestor.....	Yes
Fuel Valve.....	Yes
Overall Dimensions	93"L x 43"W x 44"H
Dry Weight	725 lbs
Replacement Filter	788283-1

* If the log splitter will be run for long periods of time in outdoor temperatures above 70°F, we recommend changing the hydraulic oil to DEXTRON III

The manufacturer reserves the right to make improvements in design and/or changes in specifications at any time without incurring any obligation to install them on units previously sold.

Any Questions, Comments, Problems or Parts Orders
Call your dealer or Dosko Customer Service 1-800-822-0295

Parts Breakdown - Exploded View - Rev D

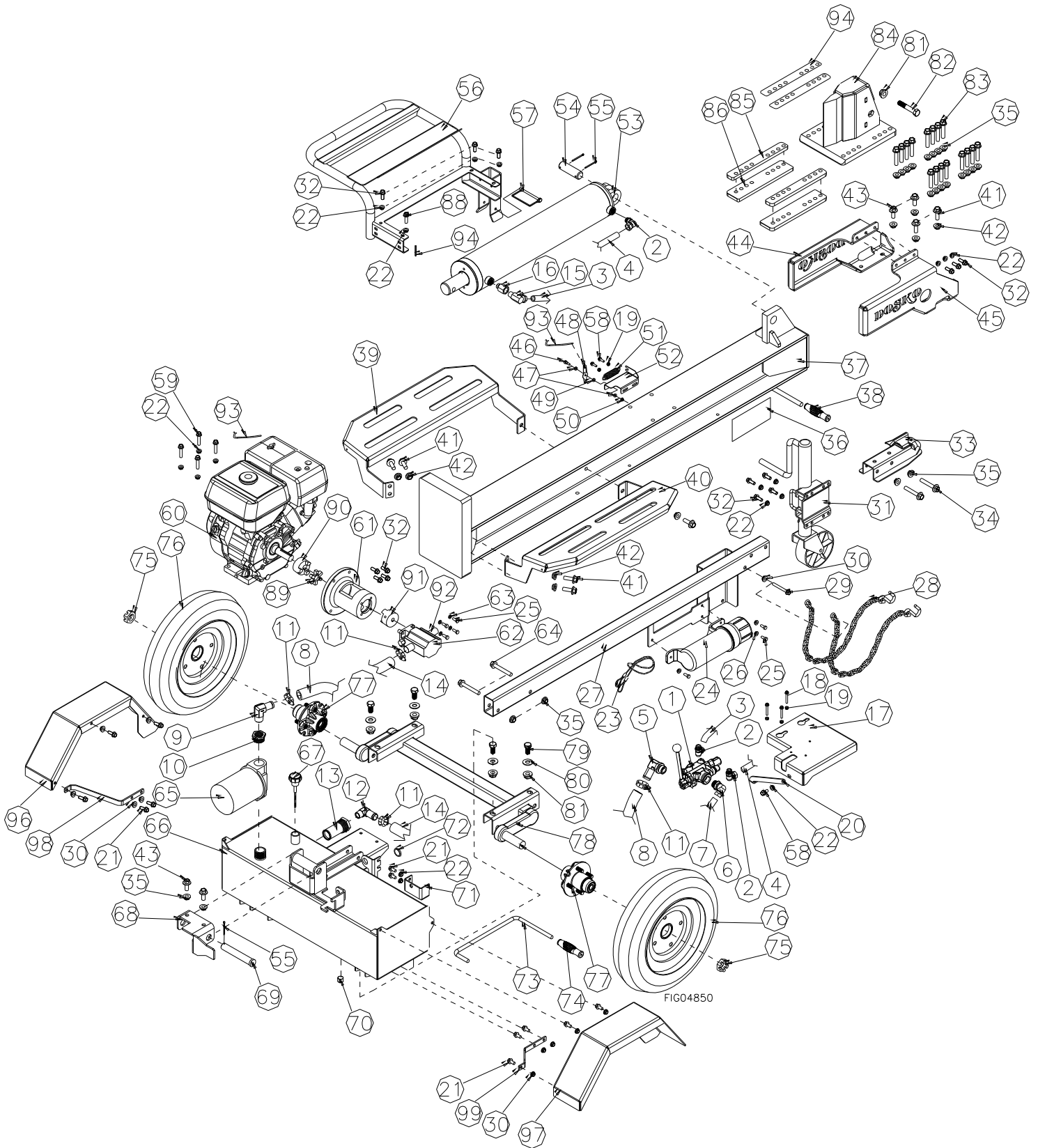

Parts Breakdown - Exploded View - Rev D

Ref#	Part#	Description	Qty
1	784034	Hydraulic Control Valve	1
2	778827	8 MOR-8FP Elbow	3
3	788209	½" x 18.5" Hose	1
4	788206	½" x 24.5" Hose	1
5	788503	1" Barb x 1-1/16 Elbow	1
6	778831	90 degree elbow	1
7	788785	½" x 48" Hose	1
8	788207	1" x 25.5" Return Line	1
9	788504	1" NPT x 1" Barb, Rt	1
10	50PRB2016	1-1/4" M x 1" F	1
11	777835	13/16" Hose Clamp	4
12	788502	¾" NPT x 1" Barb, Rt	1
13	4011	Suction Strainer 4"	1
14	788208	1" x 17" Suction Hose	1
15	50RAS8	½" Male x ½" Female, Rt	1
16	788505	¾" O-ring x ½" NPT	1
17	788173	Valve Plate	1
18	82076	¼-20 x 1.75HHSF	3
19	82222	¼-20 Nyloc Nut	5
20	788593	Valve Plate Gusset	1
21	82022	3/8-16 x .75 HHSF Bolt	13
22	82026	3/8-16 SF Nut	18
23	782689	18" Lanyard	1
24	788040	Manual Tube	1
25	82087	5/16-18 x .75 HHCS Bolt	7
26	82019	5/16-18 SF Nut	3
27	788152	Tounge Weldment	1
28	1130	27" Chain	2
29	82108	3/8-16 x 3 HHSF Bolt	1
30	82290	3/8-16 Class G Nut	11
31	789741	1000 lb Jack	1
32	82023	3/8-16 x 1 HHSF Bolt	14
33	38587	2" 3500# Coupler	1
34	82118	½-13 x 3 HHSF Bolt	2
35	82291	½-13 Class G Nut	22
36	788812	37 Ton Dosko Decal	2
37	788136	Beam	1
38	778459	Hand Grip	1
39	788177	Left Log Table	1
40	788176	Right Log Table	1
41	82033	½-13 x 1.5 Bolt	7
42	82036	½-13 SF Nut	9
43	82032	½-13 x 1.25 HHSF Bolt	4
44	788174	Left Stripper Half	1
45	788175	Right Stripper Half	1
46	82058	¼ x ¼ Shoulder Bolt	1
47	31094	#14S Brass Washer Lock	2
48	788239	Idle Control Arm	1
49	31095	¼ x 5/8 x 1/32 Nylon Wash	1
50	82065	10-24 Nylon Lock Nut	1
51	37991	Idle Return Spring	1
52	788178	Idle Control Base	1

Ref#	Part#	Description	Qty
53	787857	5 x 24 Cylinder	1
54	778592	Pin for Cylinder	1
55	82140	1/8 x 2 Cotter Pin	3
56	788163	Engine Guard	1
57	778498	Pin Catch	1
58	82009	1/4-20 x .75 HHSF Bolt	2
59	82025	3/8-16 x 1.75 HHSF Bolt	4
60	39115	GX270 Honda Engine	1
61	779683	Pump Bracket	1
62	1056	Hydraulic Pump	1
63	82100	5/16 Lock Washer	4
64	82474	½-13 x 3.5 HHSF Bolt	2
65	788283	Return Line Filter	1
66	788151	Hydraulic Tank	1
67	784455	Dip Stick	1
68	788169	Hinge	1
69	37878	1 x 6 Pin	1
70	787711	½ Magnetic Plug	1
71	788293	Latch	1
73	788295	Latch Rod	1
74	786779	½" Rubber Hand Grip	1
75	777124	1" Slotted Nut	2
76	780202	Tire	2
77	788301	Hub, Seal, Bearing Assembly	2
78	788085	38.5" Torsion Axle	1
79	82339	5/8-11 x 1.25 HHCS Bolt	4
80	82286	5/8 Flat Washer	4
81	82288	5/8-11 Class G Nut	5
82	82472	5/8-11 x 3.5 HHCS Bolt	1
83	82473	½-13 x 2.5 HHFB Bolt	16
84	788155	Wedge	1
85	788170	Keeper Spacer	2
86	788171	Keeper	2
88	82024	3/8-16 x 1.25 HHSF	1
89	777909	Coupling ½"	1
90	777912	Coupling Insert	1
91	777911	Coupling 1"	1
92	779681	2.4" Guard Insert for Pump	2
93	38477	Idle Control Cable	1
94	789451	Keeper Spacer	2
96	788180	Left Fender	1
97	788179	Right Fender	1
98	788794	Left Fender Gusset	1
99	788793	Right Fender Gusset	1

Summary of Important Safety Information for Operation



WARNING

Carefully read and make sure you understand the following safety information before using the log splitter. Improper use or maintenance of the log splitter can result in serious injury to the operator or bystanders from moving parts that can crush or cut, flying objects, escaping high pressure hydraulic fluid, or carbon monoxide poisoning.

Introduction

- **Read Manual.** Read this operator's manual and the engine Owner's Manual completely before attempting to use the log splitter. Serious injury or death can result if safety instructions are not followed.
- **Instruct operators.** The log splitter owner should instruct all operators in safe log splitter operation.
- **Intended use.** Log splitters should only be used for splitting wood logs, lengthwise with the grain. Do not use for other purposes, as unforeseen hazards may result.

Prohibition Against Modifications

Never modify or alter the log splitter in any way. Modifications can create serious safety hazards and will void the warranty.

- **Attachments.** Never add attachments to the splitter, except for authorized accessories supplied by the manufacturer with instructions for safe installation and use.
- **Engine Speed.** The maximum engine speed is preset at a safe limit. Never attempt to modify the engine speed setting to run at a higher speed.
- **Fuel/Exhaust system.** NEVER modify or add to the exhaust system, fuel tanks, or fuel lines. Fire can result.
- **Remote Control.** NEVER attach a rope, cable, or other remote device to the splitting control.
- **Splitting Wedge.** NEVER attempt to change the height or speed of the splitting wedge.
- **Pressure Setting.** NEVER increase the pressure setting of the pump or control valve.

Operator Restrictions

- **Untrained Operators.** Do not allow anyone to operate the log splitter who has not read the owner's manual or been instructed on the safe use of the splitter.
- **Minimum Operator Age.** Never allow anyone under age 16 to operate the log splitter. Anyone 16 years of age and older must be trained and supervised by a trained adult.

Safety in Moving and Towing the Log Splitter



WARNING

The log splitter is very heavy. It can cause serious injury if it rolls out of control or tips over.

Follow the safety instructions below for safely moving the log splitter.

General safety while Moving

- **Horizontal position.** Make sure the log splitter is secured in the horizontal position before moving the log splitter. DO NOT move the log splitter when it is in the vertical position because it will be unstable and could tip.
- **Hills.** Do not move the log splitter up or down hills by hand – use a towing vehicle.
- **Engine off.** Never move the log splitter with its engine running.
- **No riding.** Never allow anyone to sit or ride on the log splitter.
- **No cargo.** Never transport cargo or wood on the log splitter.

Safety During Towing

- **Read instructions.** Review towing safety instructions in your towing vehicle manual.
- **Securely attached.** Be sure the log splitter is securely attached to the towing vehicle before towing.

Summary of Important Safety Information for Operation

- **Tires.** Be sure the tires are fully inflated and in good repair before towing the log splitter. When adding air to the tires, do not over-inflate – serious injury could occur if tire explodes.
- **Added length.** Be aware of the added length of the splitter.
- **Speed Limit.** Never tow this log splitter over 55 on pavement and 45 on gravel. Faster speeds may result in loss of control.
- **Rough terrain.** Be extra cautious and drive slowly when traveling over rough terrain.
- **Under the influence.** Never tow this splitter while under the influence of alcohol, drugs, or medication.
- **On public roads.** If towing on a public road, make sure to comply with all local, state, and federal towing requirements. It is the sole responsibility of the purchaser to obtain licensing, trailer lights, safety chains or signage, as needed to comply.
- **Unattended.** Turn off the towing vehicle before leaving the splitter unattended.
- **Disconnect before operating.** Do not use the log splitter while it is connected to the towing vehicle.

Safety – Before Use

Read/instruct

- **Read manual.** Do not allow anyone to operate the log splitter who has not read the owner's manual or has not been instructed on the safe use of the splitter.
- **Review safety rules.** Before starting this log splitter, review the "Rules for Safe operation." Failure to follow these rules may result in serious injury to the operator or bystanders.
- **Know how to stop.** Be thoroughly familiar with all controls and proper use of the equipment. Know how to stop the splitter and relieve system pressures quickly if needed.

Personal protective equipment

- **Eye protection.** Always wear safety glasses or goggles when operating the machine. Pieces of log may fly out and serious eye injury can occur.
- **Boots.** Falling logs can crush feet. Always wear safety shoes or heavy boots when operating or helping to load logs.
- **Loose/dangling.** Loose or dangling apparel can become entangled in moving parts. Never wear jewelry or loose-fitting clothing.
- **Gloves.** Wear snug fitting gloves without drawstrings or loose cuffs.
- **Hearing Protection.** The use of earplugs or other hearing protection device is recommended.

Summary of Important Safety Information for Operation

Safety During Inspection/Maintenance

Always inspect your log splitter before each use, and repair as needed, to keep it in safe working condition:

- **Engine off.** Always make sure the engine is off before cleaning, repairing or adjusting the splitter, except as recommended by the manufacturer.
- **Engine debris.** Debris on a hot engine can be a fire hazard. With the engine off, clean debris and chaff from engine cylinder head, cylinder head fins, blower housing rotating screen, and muffler areas. Avoid contact with hot muffler.
- **Other debris.** Debris on moving parts can cause excess wear. With the splitter engine off, clear debris from moving parts.
- **Fuel tank / lines.** Before each use, check fuel tank and fuel lines for leaks. Any fuel leak is a fire hazard. Fix any fuel leaks before starting engine.
- **Mechanical parts.** Check to be sure that all nuts and bolts are tight to make sure the log splitter is in safe working condition.
- **Hydraulic system.** Check the hydraulic system (hoses, tubing, clamps/fittings, pump, and cylinder) carefully before each use. Do not operate the log splitter with frayed, kinked, cracked or damaged hydraulic hoses, fittings, or tubing, or if oily residue is observed on any of the components. High fluid pressures and temperatures are developed in the log splitter. Hydraulic fluid escaping through a pin hole sized opening can burn or puncture skin, resulting in wounds that could cause blood poisoning, infection, disability, gangrene, amputation, or death. Therefore, the following instructions should be heeded at all times when inspecting or servicing the hydraulic components of the log splitter:
 - Do not remove the hydraulic oil dipstick when the engine is running. Hot oil can escape causing severe burns. Allow log splitter to cool completely before removing hydraulic oil dipstick.
 - Do not adjust the pressure setting of the pump or valve.
 - Do not check for leaks with your hand. Leaks can be located by holding a piece of cardboard or wood (at least two feet long) with your hand at one end and passing the other end over the suspected area (wear eye protection). Look for discoloration of the cardboard or wood.
 - Stop the engine, disconnect the spark plug, and move all control valve handles back and forth to relieve pressure before changing or adjusting hydraulic system components such as hoses, tubing, fittings or other components.
 - If injured by escaping fluid, no matter how small the wound is, see a doctor at once. A typical injection injury may be a small puncture wound that does not look serious. However, severe infection or reaction can result if proper medical treatment is not administered immediately by a doctor who is familiar with injection injuries.
- **Spark arrestor muffler.** If the engine is equipped with a spark arrestor muffler, clean and inspect it regularly (follow manufacturer's service instructions). Replace if damaged.
- **Tires.** Be sure tires are fully inflated and in good repair before towing the splitter. When adding air to tires, do not over-inflate -- serious injury could occur if tire explodes.
- **Guards / shields.** Make sure all guards and shields are replaced after servicing the log splitter.
- **Replacement parts.** If a part needs replacement, only use parts that meet the manufacturer's specifications. Replacement parts that do not meet specifications may result in a safety hazard or poor operation of the log splitter.

Safety During Fueling

- **Gasoline is highly flammable and explosive.** You can be burned or seriously injured when handling fuel. Use extreme care when handling gasoline:
- **Fuel outdoors.** Fill fuel tank outdoors – never indoors. Gasoline vapors can ignite if they collect inside an enclosure. Explosion can result.
- **Use approved container.** Never pump fuel directly into engine at gas station. Static charge can build and ignite fuel. Use an UL approved fuel container to transfer gas to the engine.
- **Running / hot engine.** A running engine is hot enough to ignite fuel. Never add fuel or remove gas cap if engine is running or still hot. Stop the engine and allow to cool at least two minutes before adding fuel.
- **Heat / flames / sparks.** Stay away from sources of heat, flame, or sparks while adding fuel.

Summary of Important Safety Information for Operation

- **Don't overfill.** DO NOT overfill the gas tank. Allow at least 1/2" of empty space below the fill neck to allow for fuel expansion.
- **Replace cap.** Replace gas cap securely before starting engine.
- **Spills.** Clean up fuel spills immediately. Move log splitter away from spilled fuel on the ground. Wipe fuel off engine and wait 5 minutes for excess fuel to evaporate before starting engine. Gas soaked rags should be disposed of properly.
- **On skin / clothes.** If gasoline is spilled on your skin or clothes, change clothes and wash skin immediately.
- **Gasoline storage.** Store gasoline in a cool, dry place in an UL approved, tightly sealed container.

Safety in Work Site Selection

- **Spark arrestor.** If your splitter will be used near any unimproved forest, brush, or grassy covered land, then engine should be equipped with a spark arrestor. See the "Specifications" section of this manual to determine if your splitter already has a spark arrestor. Make sure you comply with applicable local, state and federal codes.
- **Hot exhaust.** Hot exhaust fumes from engine can cause fire. Position muffler at least 7' from combustible objects during operation.
- **Fire extinguisher.** Have a Class ABC fire extinguisher available as a precautionary measure when operating the log splitter in dry areas.
- **Level, dry surface.** To prevent accidental falls and equipment tip over, make sure the splitter is situated on a dry, level surface with good footing. Stay clear of areas with mud, ice, tall grass, weeds, brush, or snow.
- **Block wheels.** Always block the wheels to prevent unintended movement of the log splitter.
- **Carbon monoxide.** The running engine gives off carbon monoxide, a poisonous gas that can kill you. You CANNOT smell it, see it, or taste it. ONLY run log splitter OUTDOORS and away from air intakes. NEVER run log splitter inside homes, garages, sheds, or other semi-enclosed spaces. These spaces can trap poisonous gases, EVEN if you run a fan or open windows. If you start to feel sick, dizzy, or weak while using the log splitter, shut off the engine and get to fresh air RIGHT AWAY. See a doctor. You may have carbon monoxide poisoning.

Safety – During Use

General Safety During Use

 **WARNING:** Before starting this log splitter, review the following rules for safe operation. Failure to follow these rules may result in serious injury to the operator or bystanders.

- **Safety equipment / controls.** Always operate the log splitter with all safety equipment in place and in good working order, and all controls properly adjusted for safe operation.
- **Operating speed.** Always operate the log splitter at the manufacturer's recommended speed. The maximum speed of the engine, pump and wedge are preset within safe limits.
- **Know how to stop.** Be thoroughly familiar with all controls and with the proper use of the equipment. Know how to stop the log splitter and relieve system pressures quickly if needed.
- **Daylight only.** Only use the log splitter in daylight so you can see what you are doing.
- **Smoking / sparks.** Never smoke while operating the log splitter, and never operate near sources of sparks or flames.
- **Hot muffler.** If you are starting a warm engine, stay clear of muffler. It may still be hot enough to burn you.
- **Unattended.** Never leave the machine unattended while the engine is running.
- **Under the influence.** Never operate, or let anyone else operate, the log splitter while under the influence of alcohol, drugs, or medication.
- **Adjusting / repairing.** Always make sure the engine is off before cleaning, repairing or adjusting the splitter, except as recommended by the manufacturer. In addition, disconnect the spark plug and move all control handles back and forth to relieve system pressure *before changing or adjusting hydraulic system components* such as hoses, tubing, fittings or other components.
- **Carbon monoxide.** The running engine gives off carbon monoxide, a poisonous gas that can kill you. You CANNOT smell it, see it, or taste it. If you start to feel sick, dizzy, or weak while using the log splitter, shut off the engine and get to fresh air RIGHT AWAY. See a doctor. You may have carbon monoxide poisoning.

Summary of Important Safety Information for Operation

- **Other exhaust dangers.** Engine exhaust, some of its constituents, and certain vehicle components contain or emit chemicals known to the State of California to cause cancer, birth defects, or other reproductive harm. Avoid inhalation of exhaust.

Safety in Loading, Operating, and Unloading

- **Square log ends.** Logs that are not cut square can slide out while splitting and become a safety hazard or cause excessive force to log splitter components. Use a chainsaw to cut logs square on each end before attempting to split them.
- **Single log.** Never attempt to split more than one log at a time. Pieces of log can unexpectedly be thrown from the machine causing serious injury.
- **Split along grain.** Do not use the log splitter to split logs across the grain. Doing so will damage the log splitter and could also cause pieces of log to be thrown, injuring the operator or bystanders.
- **Forked logs.** Splitting forked logs can cause damage the log splitter. Trim the forked log with a chain saw prior to splitting the log.
- **Keep hands clear.** ALWAYS keep hands and feet away from the endplate, wedge, and partially split logs while loading, operating and unloading the log splitter.
- **Operator position.** ALWAYS operate the log splitter from the manufacturer's indicated OPERATOR POSITION. Other positions are unsafe because they can increase the risk of injury from crushing, cutting, flying objects, or burns.
- **Straddling / reaching across.** Never straddle, reach across, or step over the beam while the engine is running and the log splitter is in the horizontal position. You could trip, actuate the controls, and get seriously injured.
- **Second person.** Many accidents occur when there is more than one person involved in loading and operating the log splitter. Only one person should operate the controls. *If a second person is assisting in loading logs, the operator must NEVER actuate the Split Control Lever until the assistant and all bystanders are at least 10 feet away. NEVER allow an assistant to hold the log in place while the operator actuates the Split Control Lever.*

Loading/Unloading

- **Unsplit log pile.** Do not pile logs to be split in a place that will make you reach across the log splitter in order to load them.
- **Hold bark side.** Hold the bark side of logs when loading or positioning, never the ends. Never place your hands or any part of your body between a log and any part of the log splitter.
- **NOTE for vertical position loading:** Place the log on the endplate and turn it until it leans against the beam and is stable. If the log is too big or oddly shaped, stabilize the log with wooden shims between the log and endplate or ground. DO NOT use your leg or knee to stabilize the log. NEVER stabilize the log by placing your hand on top of the log.
- **Wedge moving.** NEVER load or unload logs while the wedge is moving.
- **Cracks.** Cracks in logs can close quickly and pinch fingers. Keep fingers away from any cracks that open in partially split logs.
- **Split log pile.** Move each log away from log splitter after it is split. Split logs left near the log splitter are a trip hazard.
- **Remove hands.** Remove both hands from log before activating Split Control Lever.
- **Hand activate.** Use only your hand to operate the Split Control Lever. Never use any other body part, or a rope, cable, or other remote device to actuate the control.
- **Returning wedge.** Once the control valve is actuated in the return direction, the wedge is designed to keep returning by itself completely and then stop automatically. Stay clear while the wedge is returning. It is still powerful enough on the return stroke to cause serious injury.
- **Log stuck on wedge.** If a log does not split completely and becomes stuck on the wedge, follow the instructions below to remove the log. A log can become stuck to the wedge if the wedge becomes embedded in the log and the log doesn't split and separate. This can happen if the log is too stringy or tough to split completely. A stuck log will move back with the wedge on the initial attempt to retract the wedge. If this happens, retract the wedge completely to allow the splitter to strip the log from the wedge. Keep hands clear of log and wedge while wedge is retracting.

⚠ WARNING: NEVER attempt to remove a stuck log by:

- Modifying the splitter.

Summary of Important Safety Information for Operation

- Adding attachments to the splitter.

Personal injury could result from log or metal pieces flying out at high speed toward the operator or bystanders, or the splitter could become damaged.

- **Changing splitting position.** Do not change splitting positions (horizontal/vertical) with the engine running. You may contact the muffler and receive serious burns. Be careful to avoid contact with hot muffler even after the engine is turned off.
- **Refueling.** Never refuel the engine until it has cooled at least two minutes.

Safety – After use

- **Return to horizontal.** If in the vertical position, turn off engine and return log splitter to the horizontal position for greater stability and to prepare for transportation. Avoid contact with hot muffler.
- **Remove engine debris.** Debris on a hot engine can be a fire hazard. With the engine off, clean debris and chaff from engine cylinder head, cylinder head fins, blower housing rotating screen, and muffler areas. Avoid contact with hot muffler.
- **Let engine cool before storing.** Let engine cool for at least five minutes before storing. A hot engine can be a fire hazard.
- **Storage location.** Store the log splitter in a location away from sources of heat, open flames, sparks or pilot lights – such as water heaters, space heaters, furnaces, clothes dryers, or other gas appliances. Even if the log splitter's gas tank is empty, residual gasoline vapors could ignite.
- **Gasoline storage.** Store extra gasoline in a cool, dry place in an UL approved, tightly sealed container. Gasoline vapors can ignite if they collect inside an enclosure.
- **Periodic maintenance.** Perform periodic maintenance as directed in this manual to keep the log splitter in safe working condition.

Disassembly Instructions

Crate Contents:

Log Splitter, 2" Ball Coupler, and Manual Bag.

Tools needed: Side cutters, hammer, crowbar, and nut driver.

1. Cut zip tie securing tow bar to packaging with side cutters. Then cut zip ties holding axle to packaging.

2. Pull jack latch and swing jack down.

Lift tongue and swing jack down. Crank jack down until the splitter sits level.

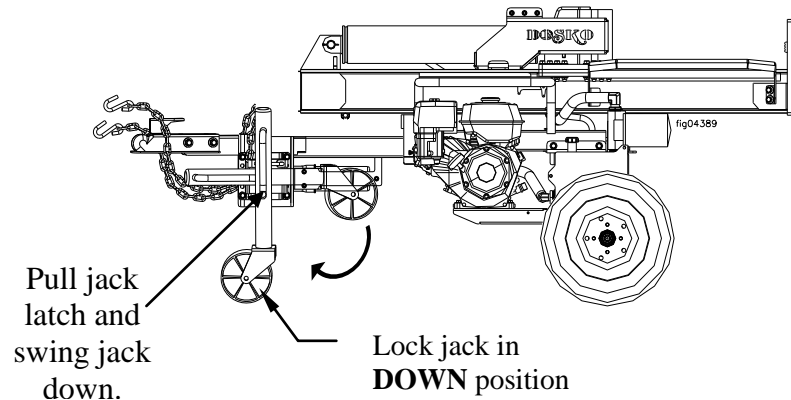

3. Remove lag bolts.

Remove lag bolts from metal bands on ends of package with nut driver. Metal bands will come off with bolts.

4. Use a hammer and crowbar to remove boards from the package, starting at the top of the crate and working down to the bottom.

Assembly Instructions

Tools needed: Adjustable wrenches and Torque Wrench

1. Install 2" ball hitch coupler.

Remove coupler from shipping position on tongue by removing bolts. Place coupler on tow bar.

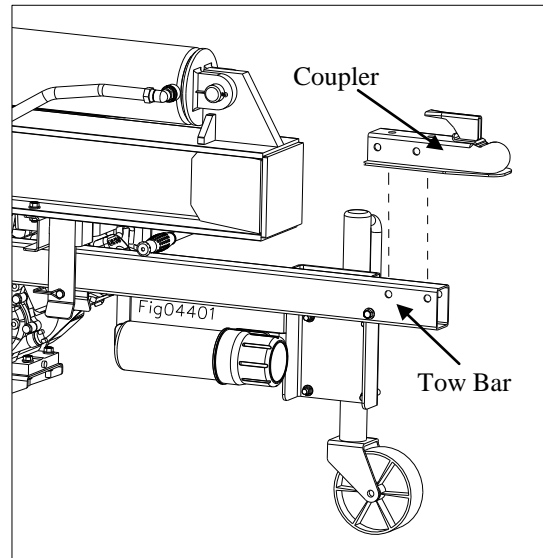

Use 1/2 x 3" Flange Bolts and 1/2" Flange Nuts to fasten coupler to the tow bar.

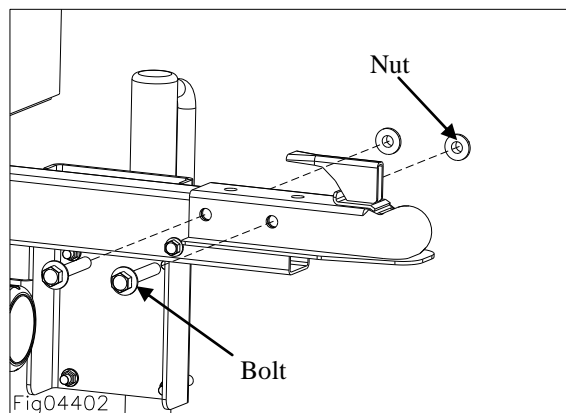

Using a Torque Wrench, Tighten **BOTH** Bolts to 57 lb-ft.

⚠ WARNING: Failure to secure these bolts could result in the coupler separating from the log splitter during towing.

This page was intentionally left blank.



**Limited Warranty Policy
August 2010**

This warranty is limited to Dosko units distributed by Great Northern Equipment Distributing, Inc. 20195 South Diamond Lake Road, Rogers, MN and sold by dealers or distributors authorized to sell that product. The following warranty applies to Dosko units purchased at retail or placed into rental service on or after August 1st 2010.

Dosko warrants each Dosko unit to be free from defect in factory materials and workmanship for a period of 90 days from date of purchase or first rental. See limitations and time parameters stated below.

DOSKO SHALL NOT BE LIABLE FOR ANY IMPLIED WARRANTIES INCLUDING THE IMPLIED WARRANTIES OR MERCHANTABILITY AND FITNESS ON ITS PRODUCTS AFTER THE 90-DAY PERIOD.

DOSKO WARRANTY ON ANY OF ITS PRODUCTS SHALL BE VOID IF THE PRODUCT HAS BEEN MODIFIED BY THE ADDITION OF PARTS OR THE DELETION OF PARTS. IN THIS EVENT, TO THE EXTENT PERMITTED BY FEDERAL, STATE OR LOCAL LAWS, DOSKO SHALL BE UNDER NO LIABILITY WHATSOEVER IN RESPECT TO ANY LOSS, DAMAGE, INJURY, OR EXPENSE ARISING FROM ANY DEFECTS IN ANY DOSKO PRODUCTS.

The warranty period, as explained in the Warranty Policy, is for 90 days from the original date of sale. The fact that our product is repaired, or parts are replaced during the original 90-day period, does not extend the expiration date of the original warranty due to any loss of time resulting from failures. This warranty shall not apply to any Dosko product which has been modified, repaired, or altered in such a manner as to affect its stability, performance or operation, nor which has been subjected to misuse, abuse, negligence or accident.

The owner is responsible for all regular maintenance as explained in the operator's manual. Neglect in regular maintenance or failure to replace normal wear items such as knives, bed knife, lubrication, oils, filters, belts, bearings, etc. may void warranty.

Your authorized Dosko dealer will repair or replace, any parts that are found to be defective within the warranty period. **ALL WARRANTIES MUST BE PRE-APPROVED** through Dosko warranty department prior to any work being done. Failure to do so will void warranty and reimbursement will not be permitted. Proof of purchase date must be provided.

In order to register for the warranty on your new Dosko unit, the dealer or rental owner should fill out and return to Dosko the enclosed warranty registration cards within ten (10) days after your purchase.

"No Warranty on Purchased Wear Parts"

Purchased wear parts (example: tires, battery, engine, belts, spark plugs, etc.) are not warranted by Dosko.

Description of Limited Warranty of Major Component Parts

Major component failures will be handled according to Manufacturer's warranty statement. Problems and defects in the engine should be referred to your authorized engine repair dealer. Other major component failures will be handled according to appropriate manufacturer's warranty statement otherwise 90 day warranty applies.

Limited Warranty of Frames/Fabrication

Dosko warrants any steel frame, tow bar, handlebar or chute for a period of two (2) years from original date of purchase to be free from defects.

20195 So. Diamond Lake Rd, Ste 100 * Rogers, MN 55374 * Toll-Free: 800.822.0295 * Fax: 763.428.4821

DOSKO

Great Northern Equipment Distributing Inc.
20195 S. Diamond Lake Rd, Ste 100
Rogers, MN 55374
Assembled in USA